



# AstroJet™ 180 PRINTER



## OPERATOR MANUAL

**Astro Machine Corp.**  
630 Lively Blvd.  
Elk Grove Village, IL 60007  
Phone: (847) 364-6363  
Fax: (847) 364-9898  
[www.astromachine.com](http://www.astromachine.com)

---

---

## SAFETY PRECAUTIONS

THIS EQUIPMENT PRESENTS NO PROBLEM WHEN USED PROPERLY. OBSERVE SAFETY RULES WHEN OPERATING THE PRINTER. BEFORE USING PRINTER, READ THIS MANUAL CAREFULLY AND FOLLOW RECOMMENDED PROCEDURES, SAFETY WARNINGS, AND INSTRUCTIONS:

### WARNING:

**Hazardous Moving Parts. Keep Fingers and Other Body Parts Away.**

### ATTENTION:

**Pièces mobiles dangereuses. Veuillez que les doigts et les autres parties du corps sont à l'écart.**

### CAUTION

**Double pole/neutral fusing. For continued protection against risk of fire, replace only with same type and rating of fuse.**

### MISE EN GUARD

**Fusible bipolaire / neutre. Pour protéger contre le risque d'incendie, remplacez avec le même type et la même classe de fusible.**

- ✓ Avoid touching moving parts or materials while machine is in use. Before clearing a jam, be sure machine mechanisms come to a stop.
- ✓ Always turn machine off before making adjustments, cleaning machine, or performing any maintenance covered in this manual.
- ✓ Use power cord supplied with machine. Plug it into a properly grounded, easily accessible wall outlet located near machine. Failure to properly ground machine can result in severe personal injury and/or fire.
- ✓ Power cord and wall plug are primary means of disconnecting machine from power supply.
- ✓ **DO NOT** use an adapter plug on line cord or wall outlet or remove ground pin from line cord. Avoid using wall outlets that are controlled by wall switches, or shared with other equipment.
- ✓ **DO NOT** route power cord over sharp edges or trap it between furniture. Make sure there is no strain on power cord caused by jamming it between equipment, walls or furniture.
- ✓ **DO NOT** remove covers. Covers enclose hazardous parts that should only be accessed by a qualified service representative. Report any cover damage to your service representative.
- ✓ This machine requires periodic maintenance. Contact your authorized service representative for required service schedules.
- ✓ To prevent overheating, do not cover vent openings.
- ✓ Use this equipment only for its intended purpose.

In addition, follow any specific occupational safety and health standards for your workplace or area.

This manual is intended solely for the use and information of Astro Machine Corp., its designated agents, customers, and their employees. The information in this guide was obtained from several different sources that are deemed reliable by all industry standards. To the best of our knowledge, that information is accurate in all respects. However, neither Astro Machine Corp. nor any of its agents or employees shall be responsible for any inaccuracies contained herein.

AstroJet™ is a registered trademark of Astro Machine Corp.

Windows is a registered trademark of Microsoft Corporation.

All other trademarks are the property of their respective holders.

All rights reserved. No part of this book may be reproduced or transmitted in any form or by any means, electronic or mechanical, including photocopying, recording, or any information storage and retrieval system, without permission in writing from the publisher.

---

---

# Table of Contents

<b>SECTION 1 – <i>Getting Acquainted</i></b>	<b>1</b>
Front View	1
Rear View	2
Control Panel	3
Optional FF-14 Friction Feeder	4
<b>SECTION 2 – <i>Install Printer</i></b>	<b>5</b>
To Install Printer	5
Contents of Packaging	5
Choose a Location	5
Connect Printer and Optional Feeder	6
Assembling Optional FF-14 Feeder	9
Install Inkjet Cartridges	10
Adjust Printer to Media	11
Optional Feeder Set-Up and Operation	12
Install Printer Driver	15
Install Printer Update Utility	17
<b>SECTION 3 – <i>Operating Printer</i></b>	<b>19</b>
Using the Touchscreen	19
Power Button	31
Transport/Pass-Through Button	32
Firmware Updates	32
Quick Menu	33
Printer Driver Properties	34
<b>SECTION 4 - <i>Maintenance</i></b>	<b>38</b>
Inkjet Cartridge	38
Cleaning Printhead	40
Purging Nozzles	41
Jams in Printer	41
Cleaning	42
Feed Rollers and Forwarding Rollers on Printer and Optional Feeder	42
Cleaning Media Sensor	43
Cleaning Touchscreen	43
<b>SECTION 5 – <i>Troubleshooting Guide</i></b>	<b>44</b>
Inkjet Print Cartridges	44
Printer	45
Touchscreen Messages	46

**TABLE OF CONTENTS**

---

<b>APPENDIX A – <i>Specifications</i></b>	<b>47</b>
Regulatory Compliance	48
<b>APPENDIX B – <i>Supplies and Optional Hardware</i></b>	<b>49</b>
Supplies	49
Optional Hardware	49
<b>INDEX</b>	<b>50</b>





## SECTION 1 – *Getting Acquainted*

### *Front View*

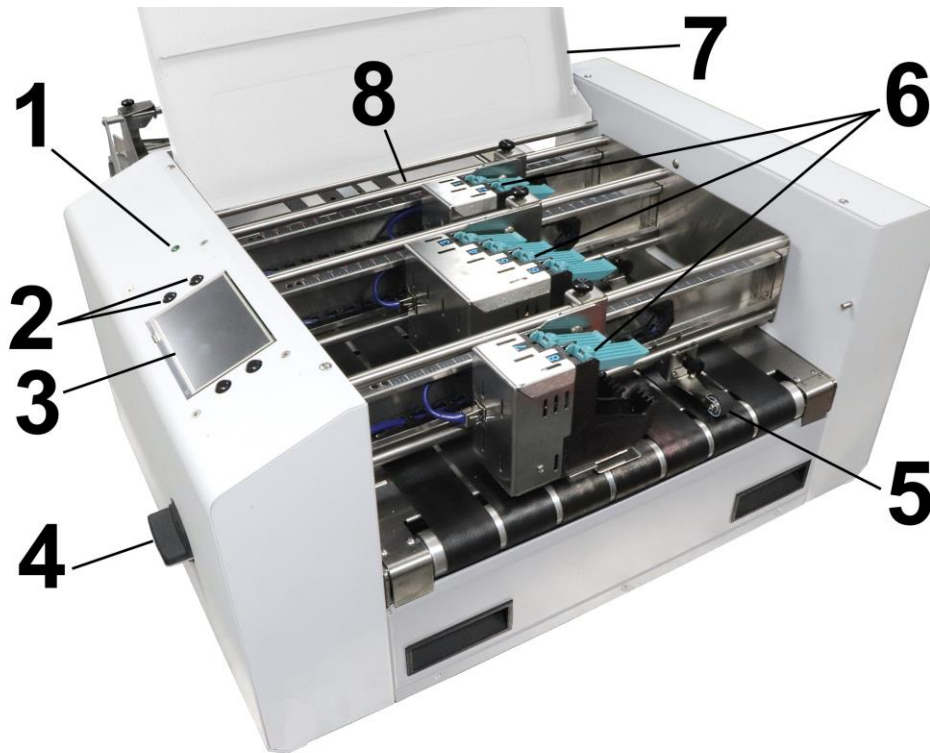

1.	<b>POWER INDICATOR LIGHT</b> – Shows that main power is ON.
2.	<b>CONTROL PANEL KEYS</b> – Used to operate often used Printer functions: <b>Quick Menu, Reset/Shutdown, Online/Offline, Pause/Print</b>
3.	<b>CONTROL PANEL TOUCHSCREEN</b> – Displays <b>Menu</b> and information about Printer status. Controls Printer functions and setup.
4.	<b>MEDIA THICKNESS ADJUSTMENT KNOB</b> – Adjusts height of Printheads to compensate for different media thicknesses. <b>NOTE: Always raise Printheads to their uppermost position when storing Printer.</b>
5.	<b>MEDIA EXIT GUIDES</b> – Hold down and guide media as it exits the Printer.
6.	<b>PRINthead CARRIAGE</b> – Has eight Printheads arranged on three rails (2-4-2) and can print and image up to 4" wide.
7.	<b>TOP COVER</b> – Encloses the Printheads.
8.	<b>MEDIA SENSOR</b> – Senses media as it enters the Printhead area. Located behind the Printhead Assemblies.

*Rear View*

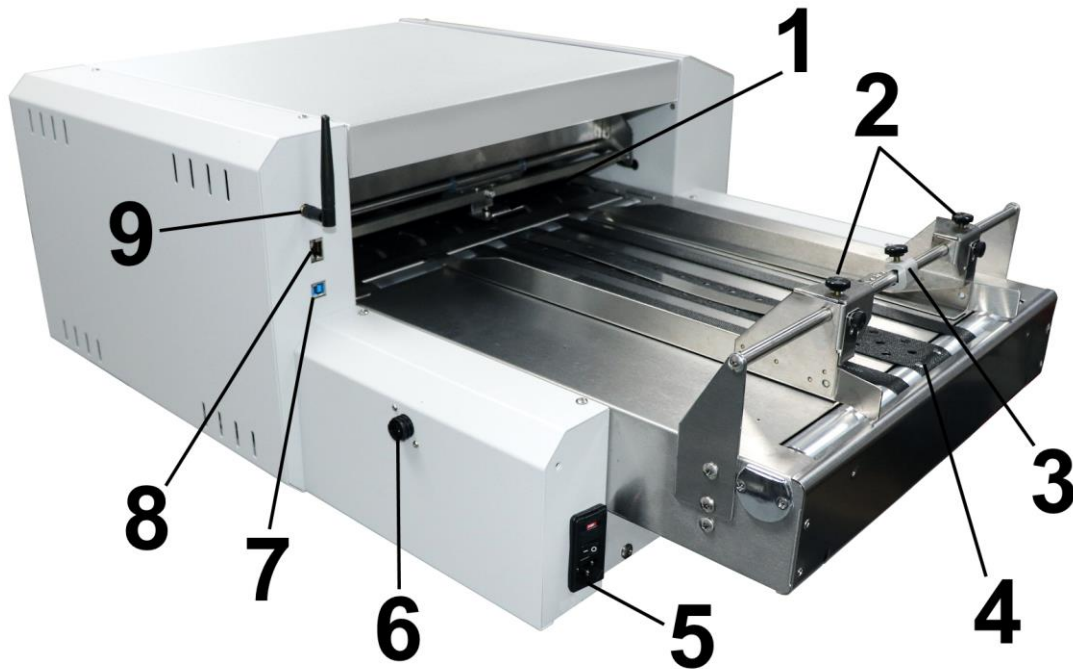

1.	<b>MEDIA FEED GUIDES</b> – Holds down media to help guide it to Printheads.
2.	<b>MEDIA SIDE GUIDES</b> – Guides and keeps media aligned while feeding to Printheads.
3.	<b>MEDIA RETAINER/ENTRY SENSOR ASSEMBLY</b> – Holds media flat when feeding to Printheads. The Media Sensor Reflector is mounted to the support rod assembly. The Media Entry Sensor is mounted directly below, under the Feed Conveyor.
4.	<b>TRANSPORT BELTS</b> – Three Transport Belts move media to the Printheads. Narrow outer belts can be repositioned to accommodate different widths of media.
5.	<b>MAIN POWER SWITCH, POWER RECEPTACLE AND FUSE</b> – Power cord plugs in here. The window panel shows what voltage the Printer is set for: 115V or 220V. <b>Switch</b> turns Printer ON and OFF. <b>Fuse</b> protects Motor from overloads. <b>CAUTION:</b> Double pole/neutral fusing. For continued protection against risk of fire, replace only with same type and rating of fuse. <b>MISE EN GARDE:</b> Fusible bipolaire/neuter. Pour protéger contre le risque d’incendie, remplacez avec le même type et la même classe de fusible.
6.	<b>PRINTER/FEEDER INTERFACE CONNECTOR</b> – Connector for optional Feeder.
7.	<b>USB 3.1 PORT</b> – Connects Printer to computer. (Also supports USB 2.0)
8.	<b>ETHERNET PORT</b> – Connect Ethernet cable for network connection.
9.	<b>WI-FI PORT</b> – Connect Wi-Fi antenna (included) to monitor or operate Printer wirelessly through your network.

## Control Panel

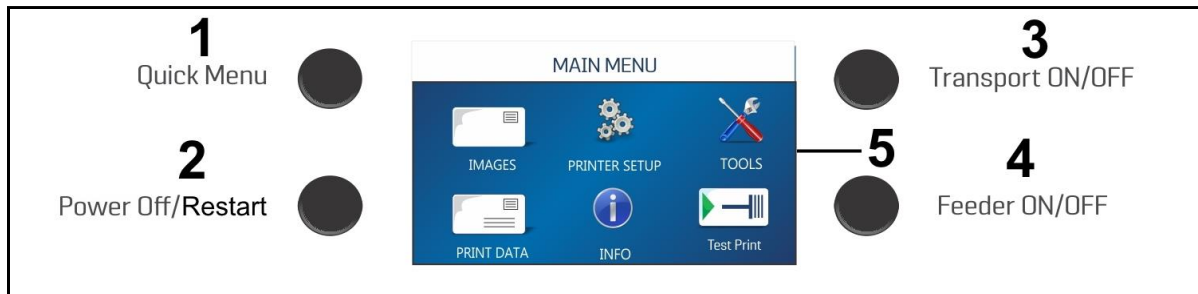

<b>1.</b>	<p><b>QUICK MENU KEY</b> – Allows quick access to often-used Printer functions without having to scroll through a number of screens. <b>Test Feed/Reprint, Horizontal and Vertical Alignment, Printer Preferences, Purge Print, and Ink Status.</b></p> <p>Press to open. Press <b>Quick Menu</b> key again to exit screen.</p>
<b>2.</b>	<p><b>POWER OFF/RESTART/UTILITY KEY</b> – The <b>Shutdown Printer</b> screen opens with 6 button options: <b>Restart, Shutdown, USB Disconnect, Sleep Now, Port Reset</b> and <b>Cartridge Initialize.</b> <b>Shutdown</b> closes Printer functions safely before shutting off Printer power with the Main Power Switch.</p>
<b>3.</b>	<p><b>TRANSPORT ON/OFF KEY</b> – Turns the Transport Motor ON and OFF. Press to turn Transport OFF. Used to operate the Printer in a non-printing "pass-through" mode when Printer is used in an in-line system.</p>
<b>4.</b>	<p><b>FEEDER ON/OFF KEY</b> – Turns the Feeder ON and OFF. Provides a quick way to print and pause a job at the Printer without using the Touchscreen or computer. Press to start printing. Press to pause a running job. Press key again to resume printing.</p> <p><b>NOTE:</b> After pausing a job, pressing this key starts both Feeder and Transport.</p>
<b>5.</b>	<p><b>CONTROL PANEL TOUCHSCREEN</b> – Use the Control Panel Buttons to open certain screens and/or use the Touchscreen arrow and screen icons to operate the Printer and set and adjust Printer settings and functions. Also check Printer status and error messages.</p>

**NOTE:** A complete description of the functions and operation of the Touchscreen can be found in Section 3 – Operating the Printer.

*Optional FF-14 Friction Feeder  
Control Panel*

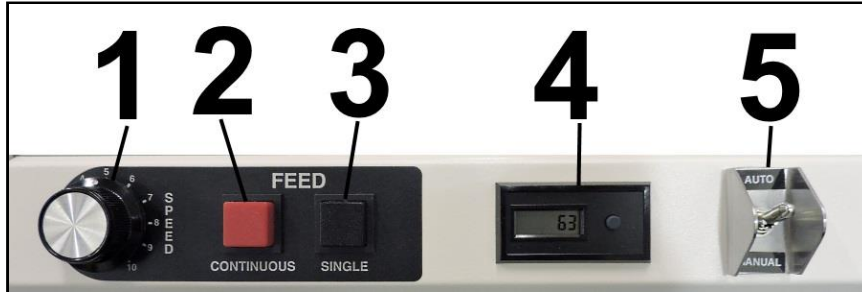

1.	<b>SPEED CONTROL</b> – Used to vary speed of Feeder in either <b>MANUAL</b> or <b>AUTO</b> mode to provide separation between pieces.
2.	<b>CONTINUOUS FEED</b> – Pressing this switch with Feed Select Switch in <b>MANUAL</b> position allows Feeder to feed continuously.
3.	<b>SINGLE FEED</b> – Pressing this switch with Feed Select Switch in <b>MANUAL</b> mode allows Feeder to feed a single piece of media.
4.	<b>BATCH COUNTER</b> – Resettable to keep track of pieces run on each job.
5.	<b>AUTO/MANUAL</b> – With Feed Select Switch in <b>MANUAL</b> , operator can feed one or continuous pieces of media by pressing <b>FEED</b> switches. When in <b>AUTO</b> , Interface controls Feeder through an external device.

*Front Panel*



1.	<b>POWER RECEPTACLE</b> – Plug power cord here. Make sure that power cord is only plugged into a properly grounded receptacle.
2.	<b>ON/OFF SWITCH</b> – Controls power to Feeder.
3.	<b>FUSE HOLDER</b> – Fuse protects electronics and motor in Feeder.
4.	<b>INTERFACE CONNECTOR</b> – Used to control FF-14 Feeder. (See “ <b>Connecting Printer and Optional Feeder</b> ” for more information.)

## SECTION 2 – *Install Printer*

### *To Install Printer*

- Choose a location for Printer and optional Feeder
- Place Feeder and connect it to Printer
- Plug in Printer and Feeder, then connect Printer to the computer
- Install Inkjet Cartridges
- Set up feed on Feeder
- Install Printer software on computer
- Create a job to be printed



### *Contents of Packaging*

1.	AJ-180 Printer
2.	Power Cord
3.	Wi-Fi Antenna
4.	USB Flash Drive ( <i>Includes Printer Driver, Operator Manual</i> )
5.	Quick Start Guide
6.	USB Cable
7.	Network Cable

### *Choose a Location*

Place Printer with Feeder on a sturdy worktable or cabinet at least 12" (30.5 cm) from any walls. Allow enough room to place Feeder on same work surface. Protect Printer from excessive heat, dust, and moisture – avoid placing it in direct sunlight. Place Feeder on Support Stand if supplied. (*Stand is supplied only when optional FF-14 Friction Feeder is used.*)

## Connect Printer and Optional Feeder

### Plugging in Printer

Make sure Printer's Main Power Switch is turned OFF.

1. Check that the Printer is set for the power to be used (115V or 220V) [A].
2. Connect one end of the power cord to the rear receptacle on the Printer.
3. Plug other end into a 115-220 Volt AC (depending on Printer voltage), 50/60 Hz. grounded outlet.

CAUTION
<p><b>DO NOT USE ADAPTER PLUGS OR EXTENSION CORDS TO CONNECT PRINTER TO WALL OUTLET.</b></p> <p><b>DO NOT USE WITH OUTLETS CONTROLLED BY WALL SWITCHES.</b></p> <p><b>DO NOT USE WITH OUTLETS THAT SHARE THE SAME CIRCUIT WITH LARGE ELECTRICAL MACHINES OR APPLIANCES.</b></p>



### Connect to Computer or Network

**USB 3.1 Port:** Plug USB cable into connector [1]. Cable used to connect Printer to computer must not exceed 6 feet long.

**Ethernet (Network) Port:** Plug network Ethernet cable into Ethernet connector [2].

**Wi-Fi Port:** Connect Wi-Fi antenna (included) to this port [3] for wireless Printer monitoring or operation through your network.

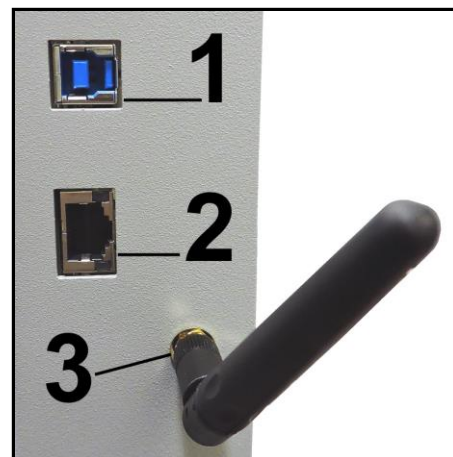

## Turning Power ON and OFF

### IMPORTANT!

CLOSE ALL COVERS AND DOORS BEFORE STARTING OR POWERING DOWN THE PRINTER.

#### Powering Up Printer:

1. Press the **Main Power Switch** located on the Feed End of the Printer. The Printer will start up.



#### Powering Down Printer:

#### WHENEVER POWERING DOWN PRINTER, ALWAYS:

1. Close all covers.
2. Tap the **Power Off/Restart Button** on the **Control Panel**. The **Shutdown Printer** screen opens. Press the "Shutdown" button.
3. Wait for the Printer to stop processing. Watch the Touchscreen [A and B]. **DO NOT touch the Main Power Switch until the Touchscreen indicates it is safe to do so.**
4. Press the **Main Power Switch** to turn Printer power OFF.



## SECTION 2 INSTALLING PRINTER

---

### Using the Restart Button:

1. Close all covers.
2. Tap the **Power Off/Restart Button** on the **Control Panel**. The **Shutdown Printer** screen opens. Press the "**Restart**" button.
3. Wait for the Printer to stop processing. Watch the Touchscreen [A]. **DO NOT touch the Main Power Switch; the Printer will come on automatically.**



### Assembling Optional FF-14 Feeder

1. Install two Side Guides using four screws [A] supplied (*two on each side*).
2. Place Feeder on a flat level surface. Feeder can be permanently mounted by removing four rubber feet, aligning Feeder on Support Stand, then reinstalling feet to hold Feeder in place.

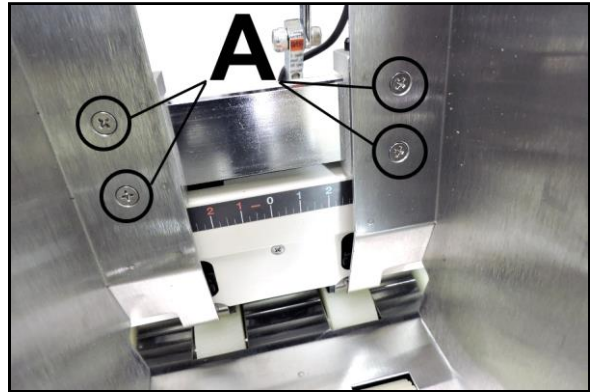

### Plugging in Feeder

Make sure that Main Power Switches on Printer and Feeder are turned OFF.

1. Connect one end of power cord to rear receptacle on Feeder.
2. Plug other end into 115-220 Volt AC, 50/60 Hz. grounded outlet.

<b>CAUTION</b>
<p><b>DO NOT USE ADAPTER PLUGS OR EXTENSION CORDS TO CONNECT FEEDER TO WALL OUTLET.</b></p> <p><b>DO NOT USE OUTLETS CONTROLLED BY WALL SWITCHES.</b></p> <p><b>DO NOT USE OUTLETS THAT SHARE SAME CIRCUIT WITH LARGE ELECTRICAL MACHINES OR APPLIANCES.</b></p>



### Connect Optional Feeder to Printer

Printer/Feeder Interface Cable must be attached to Printer and Feeder for the two machines to communicate and work together. Attach Printer/Feeder Interface Cable to the Printer and Feeder Interface ports as shown.



Printer Interface



Feeder Interface

## SECTION 2 INSTALLING PRINTER

### *Install Inkjet Cartridges*

Printer uses 8 proprietary Inkjet Cartridges. **To install Cartridges:**

**IMPORTANT!** AJ-140/AJ-160/AJ-180 Printers only work with authorized ink cartridges listed on the "Supplies and Optional Hardware" page. Other inks may become available; check with your local Astro dealer. **NOTE:** Not compatible with refills or other brands.

#### CAUTION

For continued protection against possible fire, use only genuine HP45 type Ink Cartridges, max. volume 50 ml.

#### MISE EN GUARD

Pour une protection continue contre les risques d'incendie, utilisez uniquement des cartouches d'encre authentiques de type HP45, volume max. 50 ml.

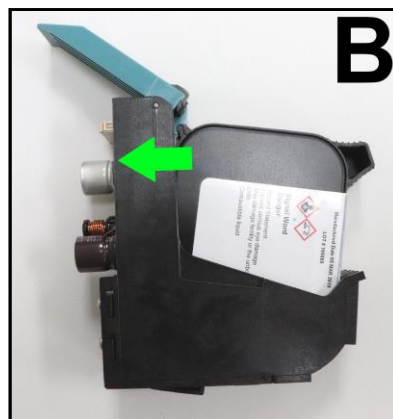
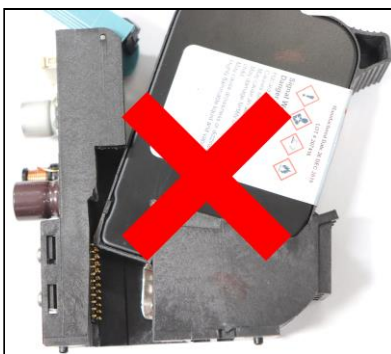
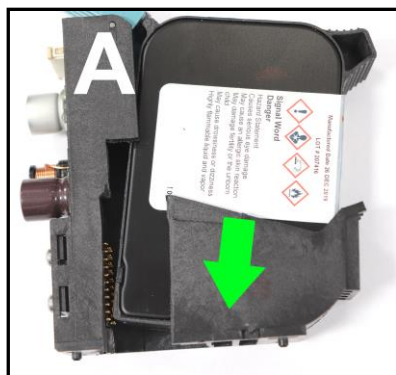

1. Remove new Inkjet Cartridge from packaging. Take care not to touch copper contacts, metal plate, or gold printhead. Remove protective tape from the Printhead.
2. [A] With Cartridge's Printhead pointing down and while keeping the Cartridge lightly in contact with the edge of the Latch Lever: Slide the Cartridge into Holder at as vertical an angle as possible. [B] Push straight back toward contacts in the Printhead Holder. **NOTE: Be careful not to bend the contact pins in the Holder or to damage the surface of the Cartridge Printhead. (See cutaway images A and X above.)**

[C] Make sure Cartridge is seated in Holder.

3. Close Latch Lever to secure Cartridge. **DO NOT** force Latch Lever into place.
4. Repeat **Steps 1-4** for remaining Cartridges.



**Ink in Cartridge may be harmful if swallowed. Keep new and used Cartridges out of reach of children. Discard empty Cartridges immediately.**

### *Adjust Printer to Media*

Place one piece of media on center of conveyor portion of Feeder. Adjust Side Guides [1] to media. Use Media Retainer Assembly [2] to help hold media down.

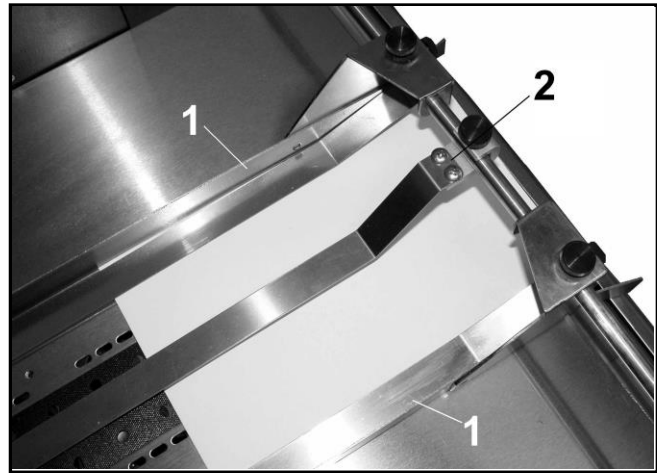

**NOTE:** Two narrow Belts can be moved by turning Printer ON and sliding Belt Guide Adjusters (*located under Conveyor Table*) in the appropriate direction until they are under the media.

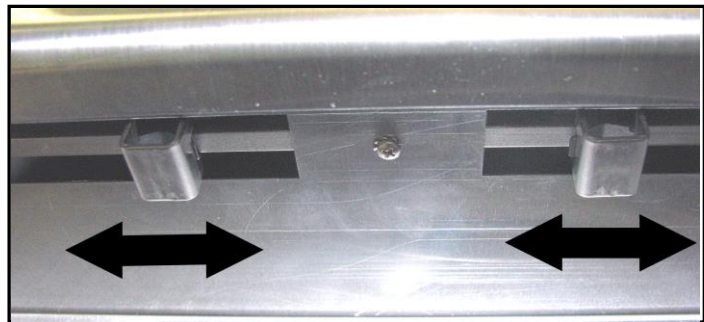

***Optional Feeder Set-Up and Operation***

1. Release the Separator Locking Lever and raise the Separators to their raised position (as shown).



2. Place the media under the Separators and release them so they rest on the media. Lock the Separators in position using the Separator Locking Lever.



3. Adjust the Side Guides to within 1/32" (0.8 mm) of the media. Then adjust the Rear Guide so that the media is raised approximately 1/2" (12 mm). (For heavy, thick media this may not be required.)



- Adjust Exit Roller pressure by pushing in on the Pressure Control Lock Button [A] and raising or lowering the Adjusting Lever [B]. For plain paper or envelopes, place the lever in the down position. For thicker material, adjust the lever so the media is fed without any bounce in the Exit Roller Assembly.

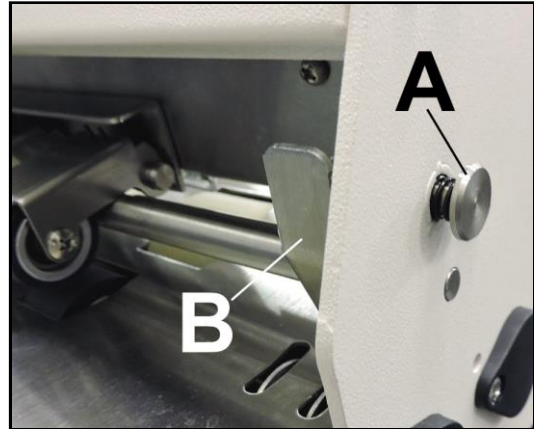

- Adjust the Jam Sensor:**  
The **Jam Sensor** detects media jams after the media has passed the **Media Sensor** on the Feeder to prevent double feeding in case of a jam or stoppage in the next piece of equipment in line (*usually a Printer*).

**Adjust the Jam Sensor one of two ways:**

[1] Position the Jam Sensor **between 0.5" to 3.5"** over the Center Conveyor Belt on the Printer (or over another dark surface) in line with the media.

Turn the Feeder ON. Place a piece of media under the Sensor to check that it is positioned correctly to sense media. Watch the Sensor LEDs. **Green** = Sensor covered, senses media. **Orange** = Sensor unblocked, not sensing media or no media present.

**NOTE: This will result in larger gaps between pieces as the Feeder will not feed the next piece until the first piece clears Jam Sensor.**

[2] Position the Jam Sensor straight up (*not pointed at anything*). This essentially disables the Jam Sensor.

**NOTE: This adjustment will result in providing the shortest gap between pieces.**

- Turn the Feeder Power switch **ON**. Set the **AUTO/MANUAL** Switch to **MANUAL** and press **SINGLE** Feed Button for single sheet feeding or **CONTINUOUS** Feed Button for continuous feeding.

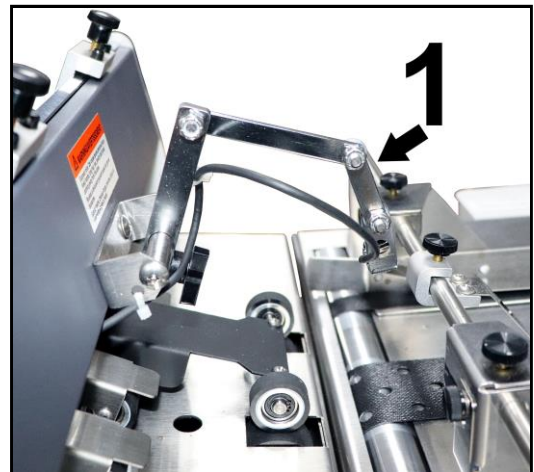

## SECTION 2 INSTALLING PRINTER

7. **POSITIONING CARTRIDGE PRINTHEADS.** Adjust positioning of the Printhead Cartridge Assemblies by loosening the locking screw(s) [A]. Slide the Assemblies as needed to print on media being used.

**IMPORTANT! Raise the Printhead Cartridge Assemblies so that they do not touch the conveyor belts before you adjust positioning.**

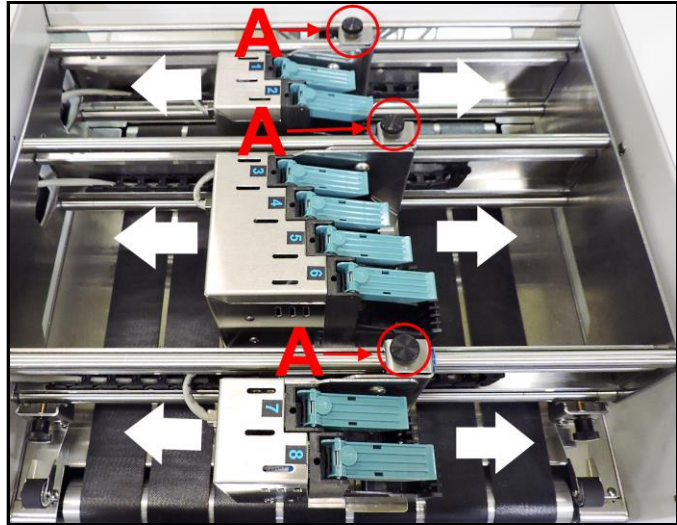

8. **Turn Printer ON.** Turn Media Thickness Knob [A] fully counterclockwise to raise the Printhead Carriage to its highest position.

Place a piece of media [B] under the Printhead Carriage. Adjust the Media Thickness Knob clockwise until the Printhead Carriage just touches the media.

Turn Media Thickness Knob counterclockwise until media [B] can be pulled from under Print Carriage with a slight pull.

**NOTE: These are initial settings. It may be necessary to adjust the Media Thickness Control to optimize print quality. Make a note of the knob position for future reference for that media.**

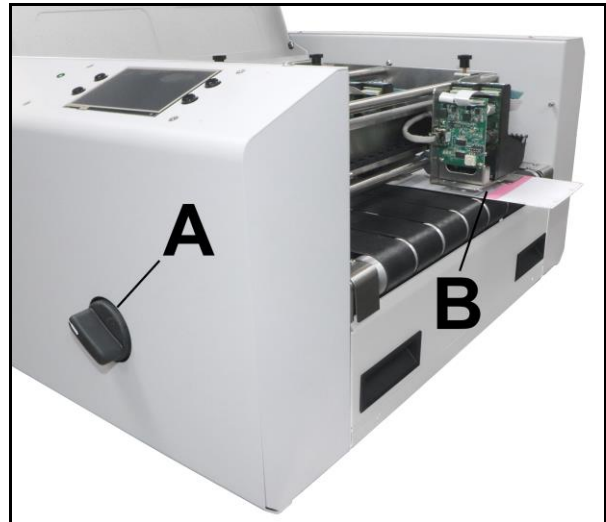

9. To test-feed media after set up, turn Feeder and Printer ON. Set **AUTO/MANUAL** Selector Switch on Feeder to **AUTO** position. Press “**Test Feed**” on the **Quick Menu Touchscreen**.

## Install Printer Driver

Download the latest Printer Driver from the Printer manufacturer's website. **NOTE: You can also use the USB Flash Drive included with the Printer to install the Printer Driver.** Make sure the USB or Network cables are connected to the Printer and your computer and that the Printer is turned on.

- If your Network requires a static IP address, see “Network Settings”.
- If you wish to use WiFi, see “WiFi Setup”.

1. **Open the downloaded Printer Driver Folder (or open the USB Flash Drive Directory):**  
Open the “Monochromes” folder.  
Open the “Driver” folder.  
Open the “Driver Version” folder.  
Select and double-click “Setup.exe”.

2. “Add, Update or Delete Printer” window opens. Click “Add New Printer”. Click **Next**>.

3. The “Connect Printer” window opens. Make sure the Printer is plugged in and switched on and that it is connected by USB, Network or WiFi to your computer. Click “Yes”.

4. The “Want to Install Printer...” window opens. If that is correct, click “Yes”.

**NOTE:** If connecting over a USB, click “No”. The next window will ask if you want to install on USB. Click “Yes”.

**NOTE:** These Printers are available as left-to-right operation or right-to-left operation models. No “R” after the Model No. indicates a left-to-right model. If an “R” appears after the Model No., the Printer is a right-to-left model.

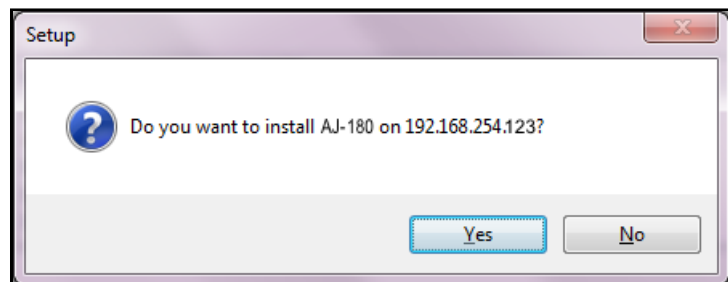
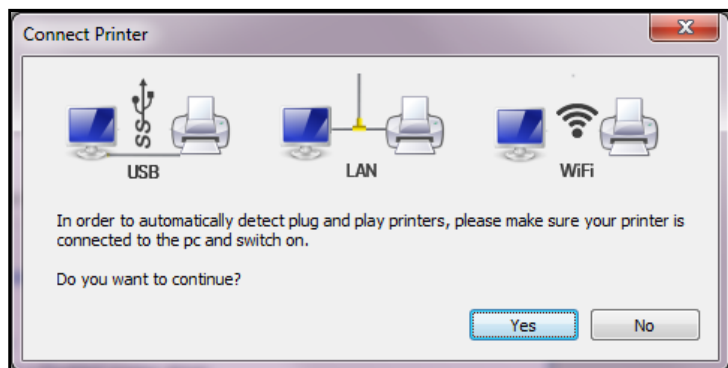
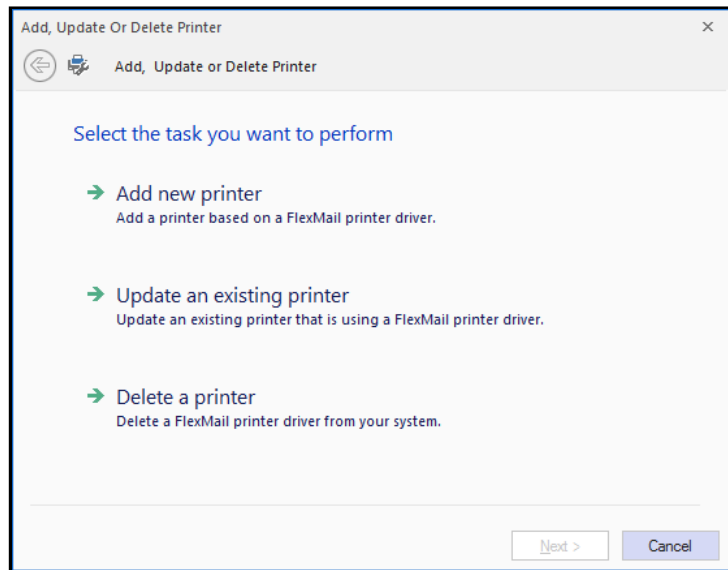

## SECTION 2 INSTALLING PRINTER

5. The Driver will load and the next screen opens to allow you to “**Type a printer name**”. Unless another printer has the same name on your system or network, ignore this step and click **Next>**.
6. Click **Finish** to complete the installation.
7. In “**Devices and Printers**” check that Printer is available and active.
8. **Using the Printer Touchscreen:** Press the **Network** icon on the **Tools** screen to open the **Network Settings** screen. Select **Network Setup** to enter the settings for connecting the Printer to your network. **Uncheck** the **DHCP** box. This will ensure that the Printer's IP address won't change each time the Printer is powered down.

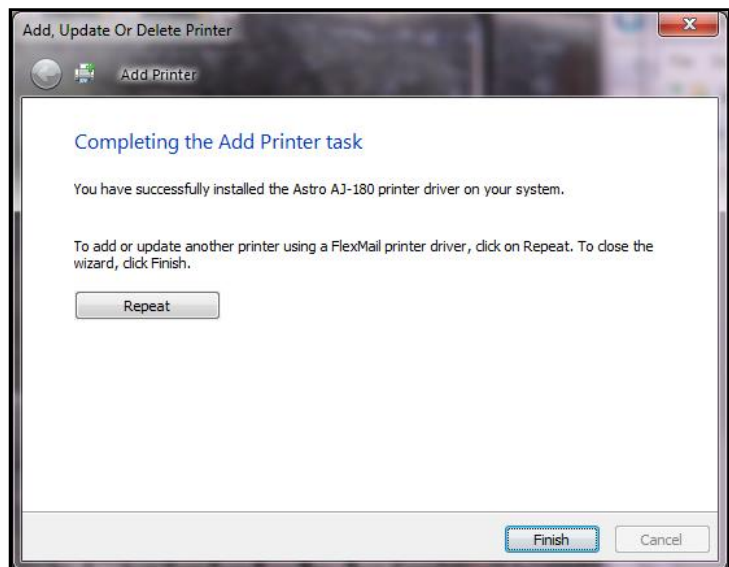
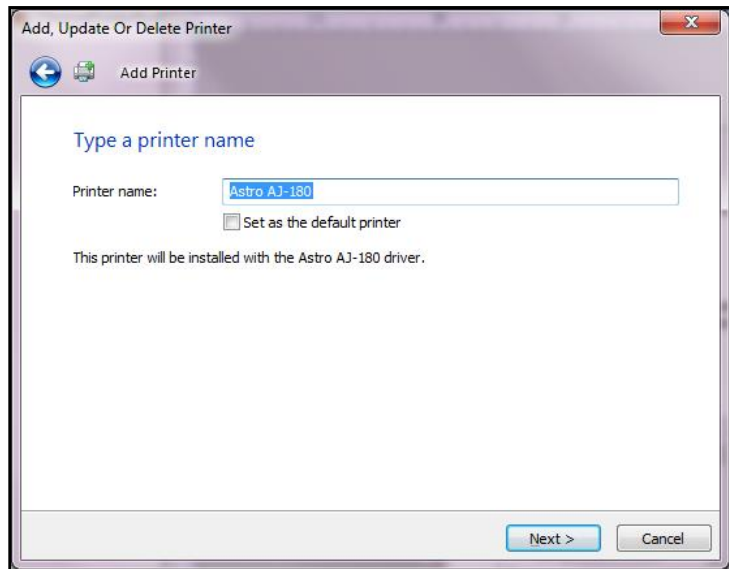
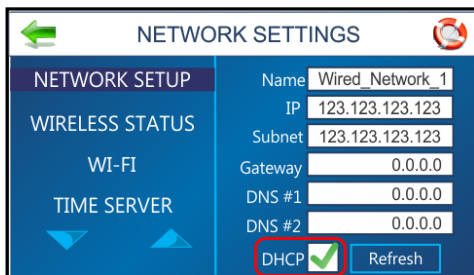

## Install Printer Update Utility

To implement Printer Firmware updates, you will need to install the **Printer Update Utility** included on the USB Flash Drive supplied with your Printer. Make sure the USB or Network cables are connected to the Printer and your computer and that the Printer is turned on.

1. **Open the USB Flash Drive:** Click the “**Monochromes**” folder. Click the “**Utility**” folder. Double-click “**Setup.exe**”.
2. The “**Printer Update Utility Setup**” window opens. Click “**Next**”.
3. The “**Select Installation Folder**” window opens. Select “**I agree...**”. Install the software in the “**Program Files**” folder (*default*) or enter a new location or click “**Browse**” for a different folder. **NOTE:** You can install the **Update Utility** to be used by anyone who logs into the computer, “**Everyone**,” or only for use when you are logged into this computer, “**Just Me**”. When ready, click “**Next**”.
4. The “**Confirm Installation**” window opens. Click “**Next**”.
5. A “**Do You Want to Allow...**” window opens. Click “**Yes**”.

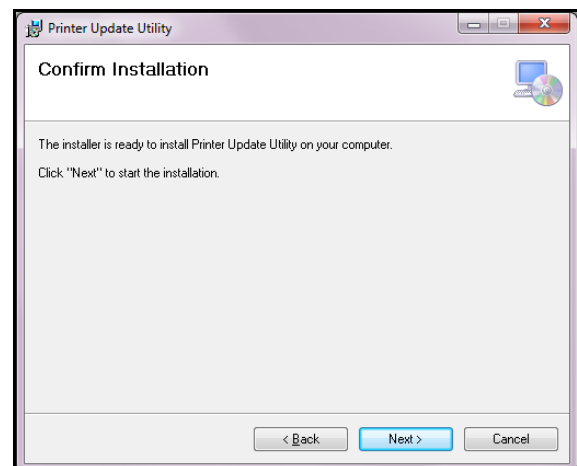
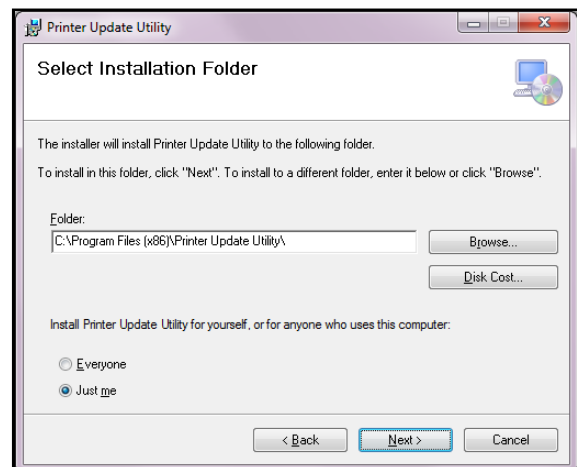
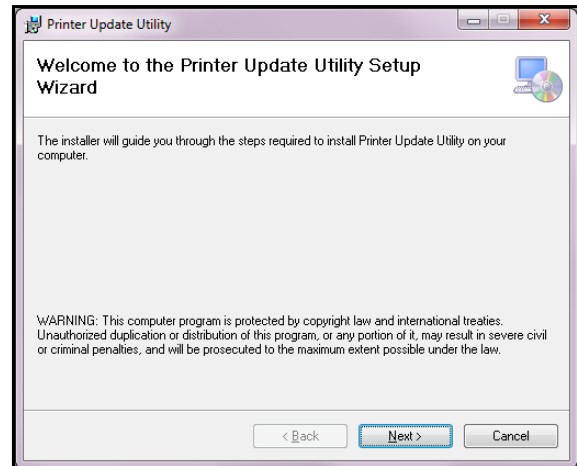

## SECTION 2 INSTALLING PRINTER

---

6. The **Printer Update Utility** is installed.
7. The “**Installation Complete**” window opens. Click “**Close**” to exit.

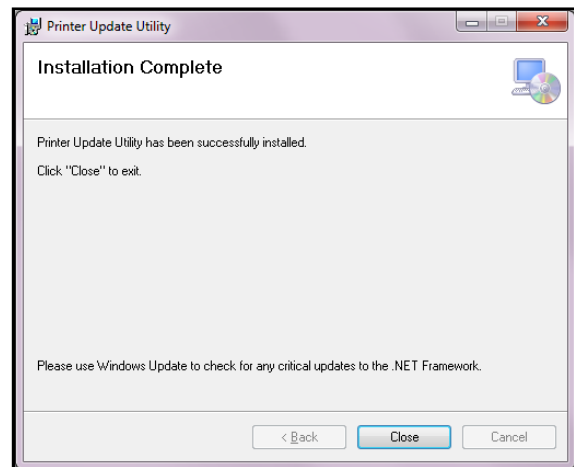
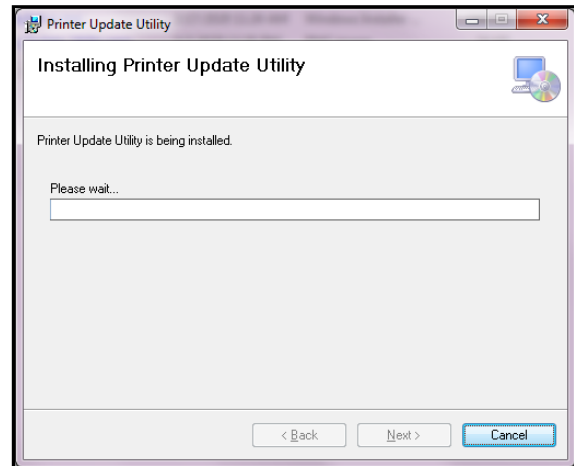

## SECTION 3 – *Operating Printer*

Once the Printer Driver is installed, you are ready to start printing. The Printer can be operated via the **Control Panel Touchscreen** or through the **Printer Driver** loaded on your computer. The “**Operating Printer**” section is divided into two parts. The first describes the function of the **Printer Control Panel Touchscreen**. The second section describes **Driver Properties** and various options available when running a job.

**Printer Driver** installed in **Section 2** should be set as the default driver. It is then accessible through your applications (*such as Microsoft Word*). Other types of applications and database management software will work in a similar manner using the **AstroJet 180 Driver**. This Section further assumes that feed is set up and Printer is connected to your computer.

### *Using the Touchscreen*

The **Control Panel Touchscreen** turns on when the Printer is turned on. Use the Touchscreen and/or Printer Control Panel keys to access various functions that help you control or customize Printer operation.

#### BASIC TOUCHSCREEN INFORMATION

**Green Arrow:** Tap or press to return to the previous screen.

**Help Icon (Life Preserver):** Tap or press the icon to open a short description of the features found on that screen.

**Cleaning:** See “**Cleaning the Touchscreen**” in the **Maintenance** section.

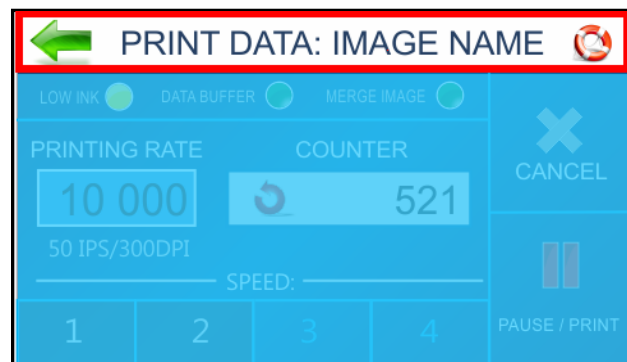

## SECTION 3 OPERATING PRINTER

---

### TOUCHSCREEN KEYBOARDS

Use the **Touchscreen Keyboards** when entering or editing information in entry boxes in features such as **Network Settings**. The appropriate keyboard opens when you tap on an **Edit Box** and/or tap within a data entry box on the Touchscreen.

- “C” to the left of the white entry box clears the box.
- “Arrow” to the right of the white entry box deletes last character entered.
- Press “Enter Arrow” on lower right of keyboard to save your entry.
- Press “Up Arrow” to toggle between upper and lower case letters.
- “SP” is the space bar.
- “123” opens the numeric keyboard.
- “#+=” on the numeric screen opens the symbols keyboard.

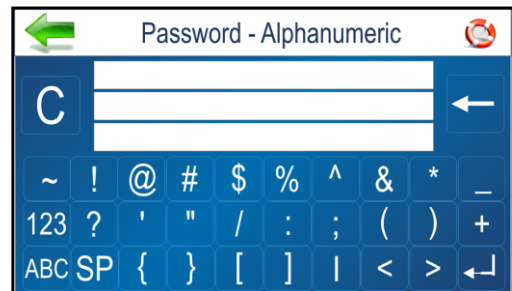
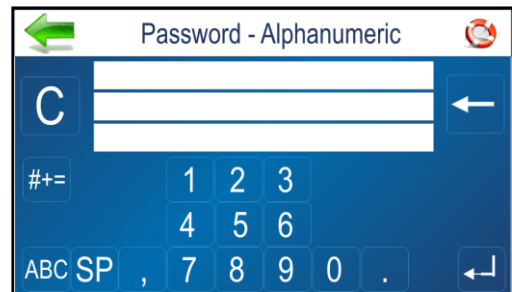
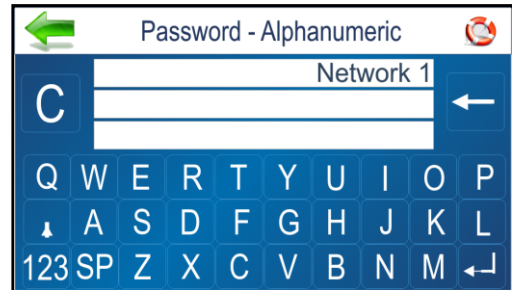

## MAIN MENU

Tap or press the icons to access features built into Printer and to customize Printer operation.

**Print Image:** Find and set up new or current jobs and/or images for printing.

**Printer Set-up:** Set Printer parameters to adjust the Printer to suit your needs.

**Tools:** Run **Ink Cost Estimator**, **Ink Status**, **Diagnostic tests**, **Network**, and **Screen Calibration**.

**Print Data:** Displays information about the job printing.

**Test Print:** Prints a test page using current adjustments and print parameters to check printing quality and Printhead alignment.



## PRINT DATA

Shows information about the job currently printing.

**Low Ink:** Indicator appears when ink is running low.

**Data Buffer:** Indicator shows whether variable data is loaded. **Red**-No variable data loaded. **Green**-Variable data loaded. **Flashing**-Variable data loading.

**Merge Image:** Indicator shows whether or not an image is loaded. **Green**-Image loaded.

**Merge Clear Button:** Allows you to clear a merge and continue printing without having to cancel the job.

**Printing Rate:** Shows how many pieces are printing per hour. Also displays the **Speed (ips)** and **Print Quality (dpi)** set for the print job.

**Counter:** Shows the number of pieces run for a particular job.

**Reset Button (inside Counter box):** Resets **Counter** to 0.

**Speed:** Shows print speeds (1-4) available for a print job.

**Cancel:** Cancels a running or paused print job.

**Pause/Print:** Press to print a job, pause a running job, or to restart a paused job. **NOTE: You can also perform these functions using the Feeder ON/OFF button on the Control Panel.**

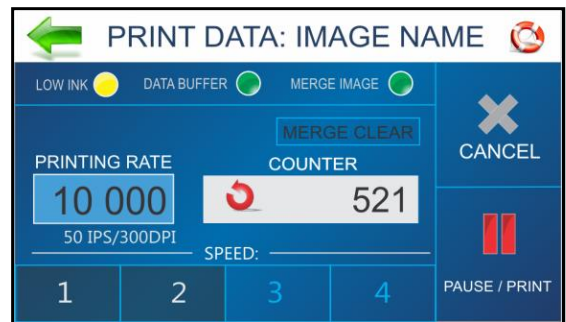

## INFO

Displays information about the Printer.

**Model Name:** Printer model.

**BIOS version:** Current version of firmware installed.

**Max. Printheads:** Number of Printheads in this model Printer. (*x's or number = printhead installed. -'s = printhead missing or problem.*)

**Firmware Notice:** Displays firmware status. The **CLEAR** button removes the notice.

**Clock:** Displays current time.

**Cartridges used:** Total number of ink cartridges emptied by the Printer.

**Pieces-Lifetime:** Total number of prints that passed through the Printer. Non-resettable.

**Jobs:** Total number of jobs run on the Printer lifetime.

**Session:** Total number of jobs run on the Printer since last power-down.

**Port(s) in Use:** Displays which Printer ports are being used.

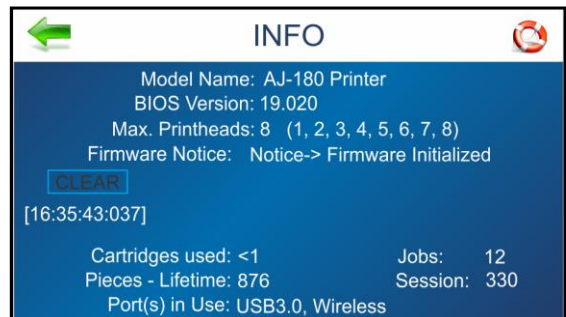

## SECTION 3 OPERATING PRINTER

### PRINT IMAGE

Pressing the **Print Image** icon on the **Main Menu** opens the **Print Image** screen. Used to find and set up new or current jobs and/or images for printing.

**File Info:** Displays current jobs/images in the **Image Library** including printing parameters.

Use the arrows to scroll through and select images from the **Printer Image Library**. Press the white button to display up to four current images simultaneously.

**Import:** Puts the Printer in **Save** mode to save a new job or image sent from the database into the **Printer Image Library**.

**Print:** Opens the **Print Set-up** screen (*see next page*).

**Delete:** Deletes the job or image from the **Printer Image Library**.



### PRINT IMAGE – FULL SCREEN PREVIEW

Tap or press the image on the **Print Image**, **Print Data** or **Reprint** screens [A]. Image will fill the Touchscreen for easier viewing [B]. Tap image again to return to normal screen view.

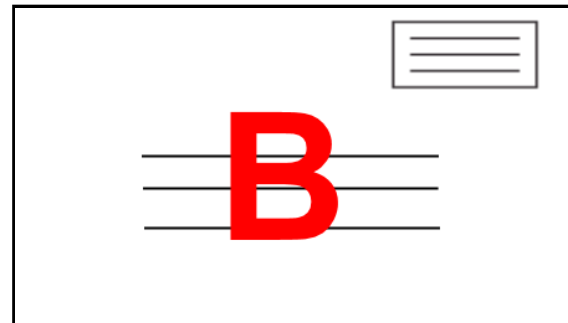

### PRINT IMAGE – IMPORT

Printer is ready to save a new image sent from the database. Send the image from your computer to the Printer as a single-page job. Image will be saved with printing parameters (*Page Size, Print Quality*).



### PRINT IMAGE – DELETE

Job or image is being permanently deleted from the **Print Image Library**.

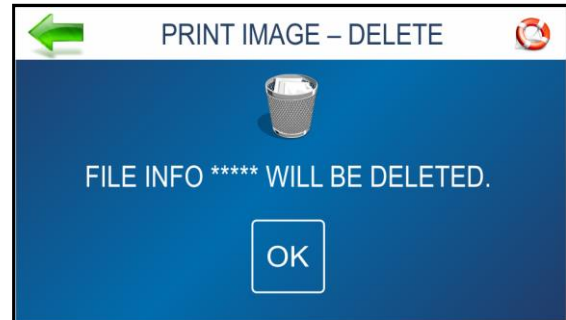

### PRINT IMAGE – SET-UP

Pressing the **Print** icon on the **Print Image** screen opens the **Print Image Set-up** screen. Once a job is loaded, the image name and dpi it was sent at are displayed at the top of the screen.

**Counter:** Enter the number of copies to be printed. Printer counts down from the number set on the screen.

**Reset button** (inside Counter box) resets Counter to **1**.

**Print Quality:** Shows **Speed** in inches per second (*ips*) and **Print Quality** (*dpi*) set for the print job.

**NOTE:** Print Quality is determined by the **Print Resolution** set in the image or print job.

**Speed:** Shows the speeds available (**1=Slowest; 4=Fastest**) for a particular job. **NOTE:** Speeds available are determined by the **Print Resolution/Print Quality** set in the image or print job.



**Merge:** Merge Image with a database. New job must match Page Size and Layout of merged image

**NOTE: To Merge with a database, the image must be saved at 600 dpi.**

**Print:** Press to start printing the job. If a Feeder is connected, the Printer Transport will start before the Feeder to ensure smooth feeding. **Print** also opens the **Print Data** screen that allows you to monitor the status of the printing job.

**Once the selected print job is loaded/printing, the Print Data screen opens:**

**Low Ink:** Indicator appears when ink is running low.

**Data Buffer:** Indicator shows status of variable data to be loaded. **Red**-No variable data loaded. **Green**-Variable data loaded. **Flashing**-Variable data loading.

**Merge Image:** Indicator shows whether or not an image has loaded. **Green**-Image loaded.

**Merge Clear Button:** Allows you to clear a merge and continue printing without having to cancel the job.

**Printing Rate:** Shows the number of pieces printing per hour.

**Counter:** Shows the number of pieces run for a particular job.

**Reset Button** (inside Counter box): Resets **Counter** to **0**. The Counter can be set to reset between jobs manually or automatically, see **Continuous Batch Counter** in **Printer Preferences**.

**Cancel:** Cancels the print job.

**Pause/Print:** Press to print a job, pause a running job, or to restart a paused job. If a Feeder is connected, the Feeder will stop before the Printer Transport to allow the last media fed to pass through.

**NOTE: You can also perform these functions using the Feeder ON/OFF button on the Control Panel.**

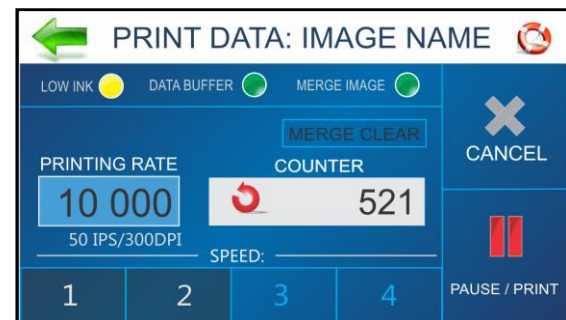

## SECTION 3 OPERATING PRINTER

### PRINTER SET-UP

Pressing **Printer Set-up** on the **Main Menu** opens the **Printer Set-up** screen. Features on this screen allow you to set Printer parameters to adjust the Printer to suit your needs.

**Ink Type:** Displays the Ink Types loaded in the Ink Cartridge Holders. Only authorized Ink Cartridges will display. Selecting an Ink Type allows editing options to be available.

**Printer Preferences:** Select from a list of Printer actions and/or set a **Feeder Stop** and **Conveyor Gap**.

**Language:** Select the language the Printer Touchscreen will display.

**Horizontal Alignment:** Fine-tune the spacing of the Printheads (1-8) in relation to each other horizontally (*side-to-side*).

**Vertical Alignment:** Fine-tune the spacing of the Printheads (2-8) in relation to each other vertically (*front-to-rear*).

**Factory Default:** Returns the Printer Setup to factory default settings.

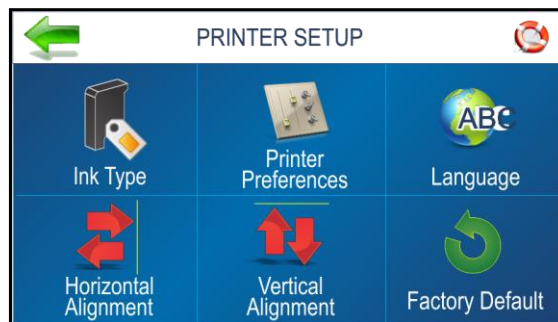

### INK TYPE

Functions found on this screen:

**Select Ink Type:** Select the recognized Ink Cartridge installed in a particular Cartridge Holder [1-8]. Tap the entry to select the Ink Cartridge. Tap the **Edit** box to open the **Ink Specifications** screen.

**NOTE: Only authorized Ink Cartridges will be recognized by the Printer. An empty cartridge holder or invalid or unprogrammed Ink Cartridge will display as “-----”. An Ink Cartridge that is programmed, but not recognized by this Printer displays as “???????”.**

**Ink Type Specifications (Paper/Pencil icon):** Displays the Ink Type and Boost entry box. Tap the **Boost** entry box to increase voltage for that Ink Cartridge up to the maximum recommended (*see below*).



### EDIT INK TYPE

Boost the voltage on a particular ink cartridge to improve print performance under certain conditions. Once entered, the Printer memory will recall this information even if the Cartridge is removed and reinstalled in this Printer later.

**CAUTION**

**Boosting the voltage above the maximum shown will damage the Ink Cartridge, Cartridge Holder and Printer.**

Press the **Boost** entry box to open the **Numeric Keyboard** to increase the voltage on a particular Ink Cartridge. **DO NOT increase the voltage more than the maximum listed on the touchscreen.**

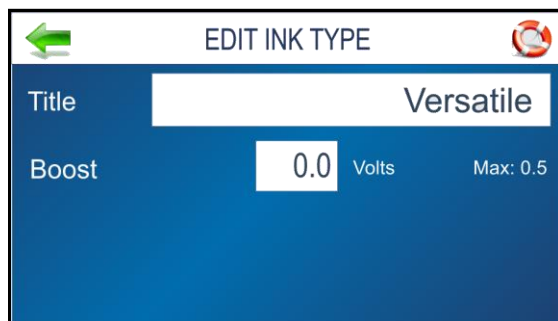

## PRINTER PREFERENCES

This menu is also available by pressing **Quick Menu** key on the Control Panel. Note that **Tray Break** also has an **Edit** icon. Tap or press the icon to open the **Edit** screen. Press ">>>>" to go to next screen. Press "<<<<" to return to the previous screen.

**Purge First Piece:** Turning this feature ON causes the Printer to send one purge pattern on the first piece. After purge is completed, the next piece will be the first record of your database. Once this feature is selected, it remains ON, even if Printer is turned OFF.

**Select** = Purge. **Deselect** = No Purge or Stop Purge.

**Automatic Feed Start:** Turning the feature ON causes Printer to start feeding once the job is sent. Printer will come **Online**, the Printer starts feeding and printing automatically. Turn this feature off to use the **Print** button on Touchscreen (or **Feeder ON/OFF** on Control Panel) to start printing. Turning the Printer ON or OFF does not affect your selection. **Select** = Auto Feed Start. **Deselect** = No Auto Feed Start.

**Keep Nozzles Alive:** Prevents unused Printhead nozzles from becoming dehydrated during a printing job.

**Select** = Nozzles to stay hydrated. **Deselect** = Nozzles do not spit. **Edit box:** Set the spitting frequency: **1x**, **2x**, **4x** (default), and **8x**.

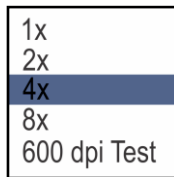

The **600 dpi Test** spits through all the nozzles at once. (*Example: This might be used to find a problem with the Printhead nozzles or to clear the printhead after sitting idle for long periods of time.*)

**Tray Break:** Printer will search for break marks (spaces between media pieces) and respond according to settings. **Select** to pause or set a gap within a print job. **Edit box** = Select and set the **Feeder Stop** and timing or select the **Conveyor Gap** and set gap/break spacing. (*See below*)

**Continuous Batch Counter:** **Unchecked** = Batch Counter resets before each job. **Checked** = Batch Counter will not reset before each job.

**Feeder Delay:** Used to lengthen the time between pieces being fed. (*Example: Jobs that require longer drying time before they are stacked.*) **Unchecked** = No Feeder Delay. **Checked** = Feeder Delay activated. **Edit Box:** Set the amount time the Feeder will pause in tenths of a second. (*See below*)

**NOTE:** This applies only to internal print jobs on the Printer (**Example: Test Print, Purge Print** and images stored in the **Printer Image Library**). Any print jobs sent to the Printer with this parameter already set in the job setup will override this feature.

**Printer Sleep:** **Checked** = Printer will go into **Sleep Mode** after being idle for a preset period of time. **Unchecked** = Printer never goes into **Sleep Mode**.



## SECTION 3 OPERATING PRINTER

### TRAY BREAK SETTINGS

**Feeder Stop:** Select and set the timer to pause/stop the Feeder at predesignated breaks during a print run. Enter time in seconds (1-60). On sensing the break mark, the feeder stops for  $x$  number of seconds.

**Conveyor Gap:** Used when Printer is set up in line with other mailing equipment (*conveyors, tabbers, etc.*)

When this feature is activated, Printer responds to the “break mark” by sending a signal to the conveyor to speed up momentarily. This creates an obvious gap between end of one set of pieces and beginning of the next. Select and set the gap on a conveyor between predesignated breaks during a print run. Enter the distance between the Media Sensor and the Conveyor. The Printer sends a delayed signal to an external device and continues to feed.



### FEEDER DELAY

**Feeder Delay:** Select to lengthen the time between pieces being fed. (*Example: Jobs that require longer drying time before being stacked.*) **NOTE:** This applies only to internal print jobs on the Printer (**Example: Test Print, Purge Print** and images stored in the **Printer Image Library.**) Jobs sent to the Printer with this parameter already set will override this feature. **Unchecked** = No Feeder Delay. **Checked** = Feeder Delay activated. **Edit Box:** Set the amount time the Feeder will pause in tenths of a second.

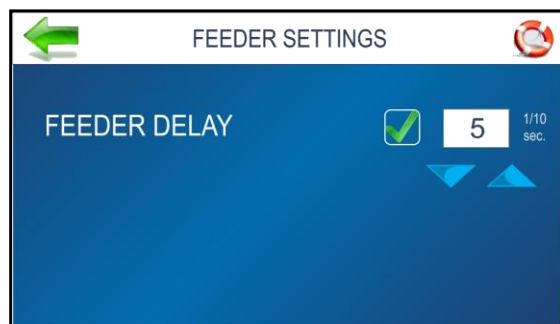

### SELECT LANGUAGE

Select the language that the Printer Touchscreen will display.



### FACTORY DEFAULT

Restores **all** operator initiated adjustments and settings to factory settings.



## HORIZONTAL ALIGNMENT

Adjusts offset of individual Printheads (*side-to-side*) offset to fine tune horizontal positioning of the printout.

**Horizontal Alignment** is also accessible by pressing the **Quick Menu** key on the Control Panel.

**Heads (1-8):** Align individual Printheads (*side-to-side*) up to  $\pm 100.0$  microns in 5.0 micron increments.

**To use:** Select the desired Printhead. Move the bar in the desired direction by pressing the directional arrows.

**Reset:** Horizontal alignment resets to **00.0** (*default*).

**Test Print:** Prints a test page using current adjustments and print parameters to check printing quality and Printhead alignment.

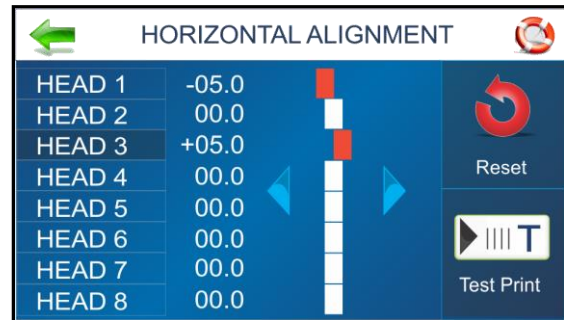

## VERTICAL ALIGNMENT

Disables the top nozzles in individual Printheads to remove any overlap to fine tune vertical positioning of the printout.

**Vertical Alignment** is also accessible by pressing the **Quick Menu** key on the Control Panel.

**Heads (2-8):** Adjust individual Printheads up to  $\pm 1.0$  microns in 0.1 micron increments.

**To use:** Select the desired Printhead. Move the bar in the desired direction by pressing the directional arrows.

**Reset:** Vertical alignment resets to **0.0** (*default*).

**Test Print:** Prints a test page using current adjustments and print parameters to check printing quality and Printhead alignment.



## PRINTER TOOLS

Press **Tools** icon on **Main Menu** to open the **Tools** screen.

**Estimator:** Select to set up an **Ink Cost Estimate** for a particular print job. The Printer runs, but does not print a preset sample number of pages (*up to 50 pages*) of the job to be printed. (*Set the number of pages in the Print Driver.*) The **Estimator** then determines the estimated ink cost for the entire print job.

**Ink Status:** Select to view the percentage of ink left in the ink cartridges and the estimated number of prints remaining for each cartridge at a selected resolution, based on last page printed.

**Diagnostic:** Select to run diagnostic tests on key Printer systems and components.

**Network:** Set up access to a network. Also set up **Wi-Fi** capability for wireless access to a network. **Wireless Status** displays network information about the Wi-Fi connection. The **Time Server** displays information about the source used for date and time when the Printer is connected to an Internet-connected network.

**Screen Calibration:** Set the touch pressure (*sensitivity*) desired to activate the Touchscreen.

**Read and Print:** When Printer is operated as part of a system, activating **Read and Print** allows the Printer Transport to run continuously while receiving and printing individual data from a barcode scanner (*like a name and address for an envelope for an addressed preprinted insert*). Switch the feature ON/OFF from the **Read & Print Settings** screen.

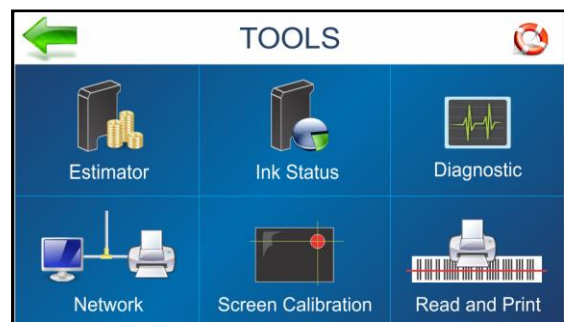

## SECTION 3 OPERATING PRINTER

### INK ESTIMATOR

This tool estimates the cost of ink for a particular print job. The Printer runs and simulates printing a preset number of pages. Set the job to print 1-49 pages (*in the Print Driver*) for the printer to make the estimate. Generally, the higher the number of pages sent, the more accurate the estimate.

**NOTE:** It is recommended that **Purge First Piece** be turned off. This will use much less ink and increase the accuracy of the estimate.

**Ink Cartridge Cost:** Tap/press the entry box to enter the cost of the ink cartridges.

**Number of Pages:** Tap the entry box to enter the total number of pages for a given job.

**Start Estimation Mode:** Tap or press to start the Ink Estimator.

**Estimated Ink Cost:** Displays the estimated ink cost for the entire print job.

### INK STATUS

Shows the percentage of ink remaining in each Ink Cartridge and the estimated number of prints remaining at a selected resolution. (*Resolution is selectable.*)

**NOTE: Estimation is based on the last page printed.**

“-----” Indicates no Ink Cartridge present or an unrecognized, unprogrammed Ink Cartridge.

“???????” Indicates an Ink Cartridge not programmed for this Printer.

**Ink Status** is also accessible by pressing the **Quick Menu** key on the Control Panel.

HEAD#		%	LIFE	
[1]	AMC-Versatile	100	10 000	150
[2]	-----			200
[3]	AMC-2580	100	10 000	
[4]	???????????			300
[5]	AMC-Standard	100	10 000	
[6]	AMC-Standard	100	10 000	
[7]	AMC-Versatile	100	10 000	600
[8]	AMC-Standard	100	10 000	

## DIAGNOSTICS

Runs tests on Printer components and systems listed on the screen at variable speed.

**To run Test:** Remove media from the Printer. Press **Start Test** to start the diagnostic cycle. Press again to stop. While **Test** is activated, run one piece of media through the Printer to test the Sensor function. The **Test** cycles through each component automatically. Green lights indicate component is functioning properly. If an external Feeder is connected, pressing **Test** starts the Printer Transport first and then the Feeder. Pressing **Stop** stops the Feeder first and then the Printer Transport to eject last media fed.

**NOTE:** After running one piece, verify that the piece length was measured accurately. If the piece fed through, but no piece length was displayed and the Sensor condition still shows red; stop this test, power off the Printer and clean the Media Sensor.

If the piece measured longer than the actual piece length; the piece is probably slipping or hesitating as it feeds. In this case, check or adjust the Feeder Sheet Separators and check and adjust the Media Thickness setting.

**Feeder:** Checking/unchecking the **Feeder** checkbox tests the Feeder and Feeder relay function. **No External Feeder Connected** – Checking/unchecking the box turns the feeder relay on and off. (*Listen for relay clicking.*) **External Feeder Connected** – Only the Feeder will start and stop.



## NETWORK SET-UP

Press the **Network** icon on the **Tools** screen to open the **Network Settings** screen. Select **Network Setup** to enter the settings for connecting the Printer to your network. Enter the Printer Name, IP address, Subnet address, Gateway address, DNS #1 and DNS #2 and select or deselect DHCP as needed. **Refresh** refreshes/updates the network connection.

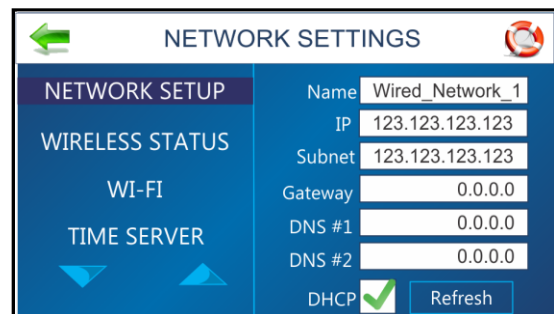

## WIRELESS STATUS

Once the **Network** and **Wi-Fi** are set up, this screen displays information about the wireless network connection.

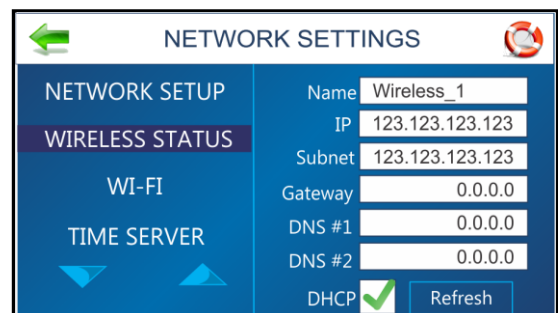

## SECTION 3 OPERATING PRINTER

### WI-FI SET-UP

Press the **Network** icon on the **Tools** screen to open the **Network Settings** screen. Make sure the Wi-Fi antenna (*included*) is connected to the Printer's Wi-Fi port.

1. Select **WI-FI**.
2. Select the desired Network from the list of **Wi-Fi Networks**.
3. Enter **User ID** and **Password**. Click **OK**.
4. Screen will show if you are connected to the Network. If connection fails, try again. Check that you are connecting to the correct Network. Check User ID and Password.
5. Click **Disconnect** to end connection.

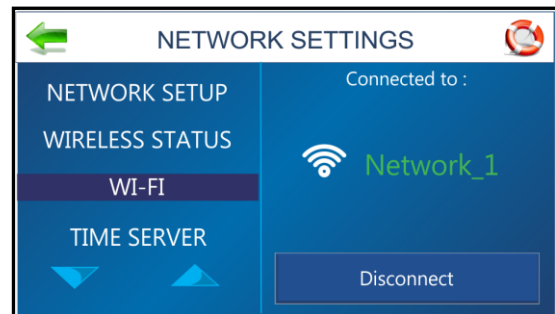
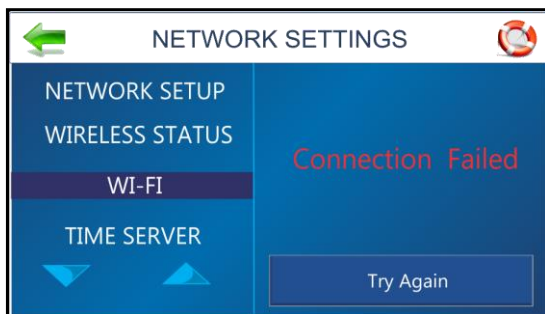
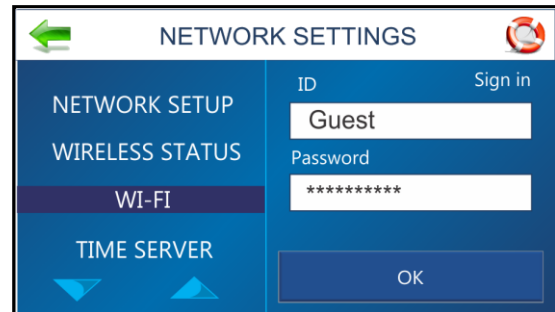
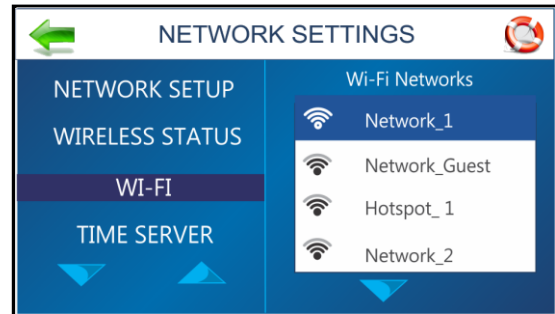

### TIME SERVER (DATE AND TIME)

Displays the IP address of the Time Server being used and/or the Time Server's network name.

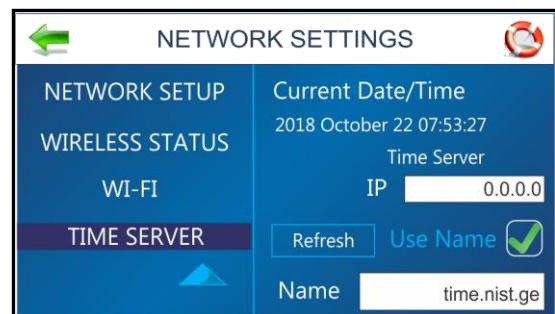

## TOUCHSCREEN CALIBRATION

Adjust the touch pressure (*sensitivity*) needed to activate functions on the Touchscreen. (*Lower percentage = less pressure, more sensitive. Higher percentage = more pressure, less sensitive.*) Follow instructions on the screen to perform the calibration. **Time Remaining** counts down the 15 seconds given to complete each step. A screen message informs you if the calibration succeeded or failed.

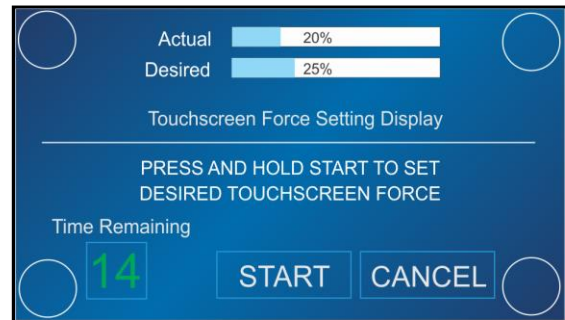

## READ AND PRINT

When the Printer is integrated as part of an in-line system, **Read and Print** allows the Printer Transport to run continuously while receiving and printing individual data from a barcode scanner (*like a name and address for an envelope for an addressed preprinted insert*). Switch the feature ON/OFF by checking/unchecking the box on the **Read & Print Settings** screen.

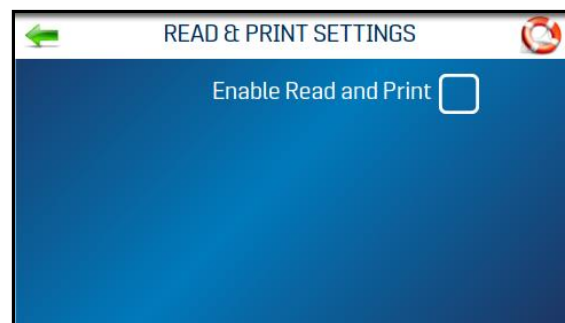

## Power Button

When the **Power ON/OFF** button on the Control Panel is pressed, the **Shutdown Printer** screen opens.

### Functions found on this screen:

**Restart:** Stops and restarts the Printer's software and electronics.

**Shutdown:** Safely shuts down software and powers off Printer. Once Printer shuts off you can safely turn the Main Power Switch OFF.

**USB Disconnect:** Disconnects or reconnects Printer communication with the USB Port.

**Sleep Now:** Puts the Printer in Sleep Mode. Wakes when the Display Screen is touched or a job is sent to the Printer through the USB or network.

**Port Reset:** Clears any jobs being sent to the Printer. **Example:** After a job is cancelled at the Printer, the remainder of the job may continue to be sent by the computer. This may cause the Printer to get “stuck” because it can no longer read the job. Press the **Port Reset** button to fully clear the job. **NOTE:** Usually once the **Power ON/OFF** button on the Control Panel is pressed, this action happens automatically and the **Port Reset** button will be inactive. If the **Port Reset** button is still active, you can press it to clear the job.

**Cartridge Initialize:** Resets/reestablishes communication between the printhead cartridges and the Printer.

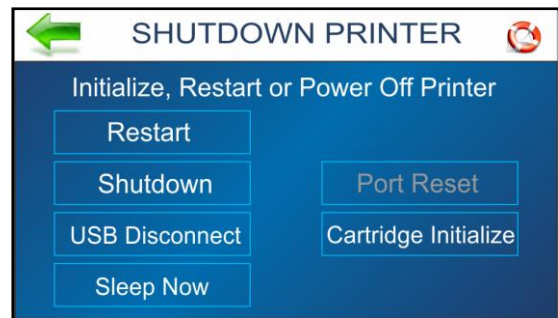

### *Transport/Pass-Through Button*

Pressing the **Transport** button on the Control Panel opens the **Transport ON/OFF Control** screen. Turning this feature on allows the Printers transport to operate without printing. This can be used for short duration to eject any media under the Printheads. It can also be used to operate the Printer in a continuous non-printing "pass-through" mode when the Printer is used in an in-line system, but is not needed for a particular job. Press the **RUN** button to start the Transport. Press **STOP** to stop the Transport.

**Adjust Printer Speed:** Generally, use the slowest speed (**1=Slowest**) to eject media. When operating the Printer as a "pass-through" device, tap one of the available speeds listed at the bottom of the screen (**1=Slowest; 4=Fastest**).

**NOTE:** Ideally the Printer speed should be the same or slightly slower than the next machine in line.

Press the **Transport** button on the Control Panel to exit the **Transport Control** screen.



### *Firmware Updates*

#### **To install a firmware update:**

Once a firmware update is sent to the Printer, the "**Firmware Updates**" screen appears on the Printer's Touchscreen. It will also appear when the **Power** button on the Control Panel is pressed. The screen indicates how many update files are available. **NOTE:** If no firmware updates were sent to the Printer, the normal **Shutdown Printer** screen appears.

- Press "**Install Updates**" to load the new firmware.
- Press "**Postpone**" to install the firmware at a later time. **NOTE:** The **Firmware Updates** screen will appear each time the Control Panel **Power** button is pressed until the firmware update is installed.
- **Verify update installed:** Check the **Info** screen to verify that the firmware version matches the updated firmware version.



## Quick Menu

Allows quick access to often-used Printer functions without having to scroll through a number of screens. Open by pressing the **Quick Menu** key on the Control Panel. Press **Quick Menu** key again to exit the screen.

**Test Feed/Reprint:** Default is **Test Feed**. If no data is present, this button allows you to test feed blank sheets of media. In case of a Printer jam or double feed, the **Test Feed** button becomes **Reprint**. Recover missed or misprinted pieces by pressing **Reprint**. Use the arrows to go back to the initial misprinted piece (*or further back if desired*) to start reprinting. Press **Print** to start printing.

**Purge Print:** Prints an ink pattern at 600 dpi to clear all of the ink nozzles in all of the ink cartridges.

**Horizontal Alignment - Heads (1-8):** Adjust offset of individual Printheads (*side-to-side*) up to  $\pm 100.0$  microns in 5.0 micron increments.

**Vertical Alignment - Heads (2-8):** Disables top nozzles in individual Printheads to reduce nozzle overlap. Adjust up to  $\pm 1.0$  microns in 0.1 micron increments.

**Printer Preferences:** Select and set various Printer features including **Purge First Piece**, **Automatic Feed Start**, **Keep Nozzle Alive**, **Tray Break**, **Continuous Batch Counter**, **Feeder Delay** and **Printer Sleep**.

**Ink Status:** Shows the percentage of ink remaining in each Ink Cartridge and the estimated number of prints remaining at a selected resolution.

**Resolution** is selectable.

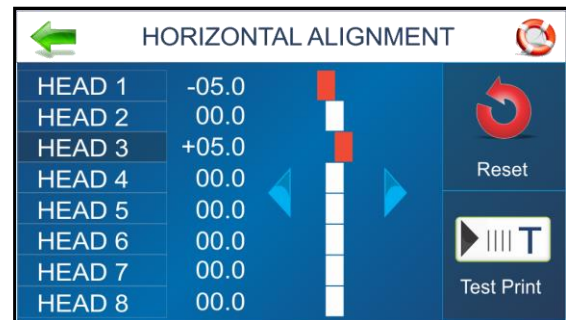
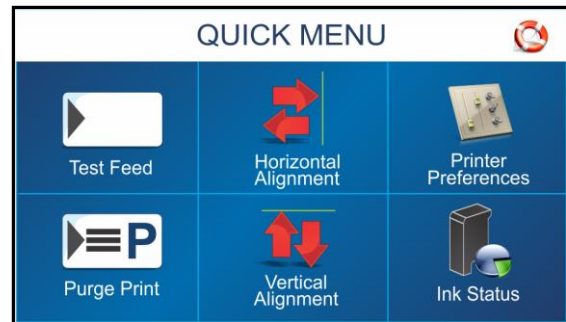

HEAD#		%	LIFE	
				150
[1]	AMC-Versatile	100	10 000	200
[2]	-----			
[3]	AMC-2580	100	10 000	300
[4]	???????????			
[5]	AMC-Standard	100	10 000	600
[6]	AMC-Standard	100	10 000	
[7]	AMC-Versatile	100	10 000	
[8]	AMC-Standard	100	10 000	

## SECTION 3 OPERATING PRINTER

### *Printer Driver Properties*

**Printer Driver** describes to the Printer how to print your job. It controls Printer operation and allows you to send fixed and variable text and graphics to the Printer. Within your data management software is a “**Print**” function. In that “**Print**” function is a **Properties** button. Through **Properties** you can control the Printer’s output. Use the **Properties Windows** to customize the Printer’s output.

To start printing, click **File**, then **Print**. “**Print**” window opens. To print the job, click **Print**.

To use special features built into Printer Drivers, clicking “**Printer Properties**” opens the **Document Properties Window**.

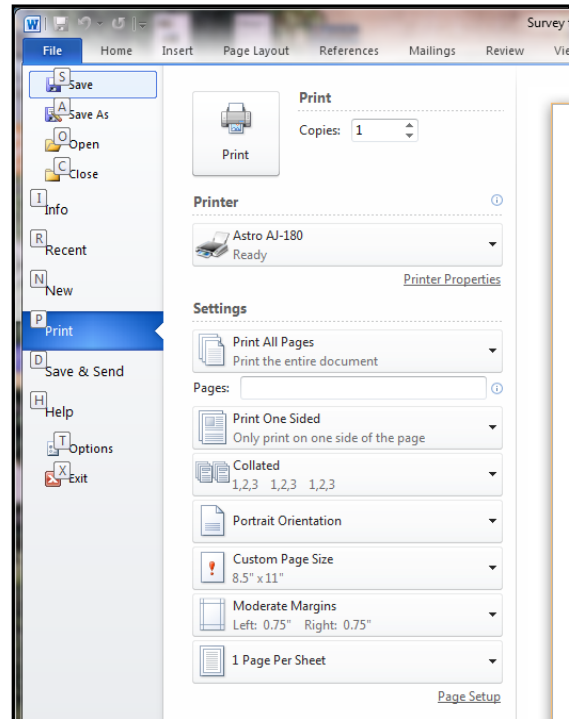

The **Layout** screen opens. The **Layout Tab** lets you select **Portrait** or **Landscape** orientation.

Clicking the “**Advanced**” button opens the “**Advanced Options**” screen.

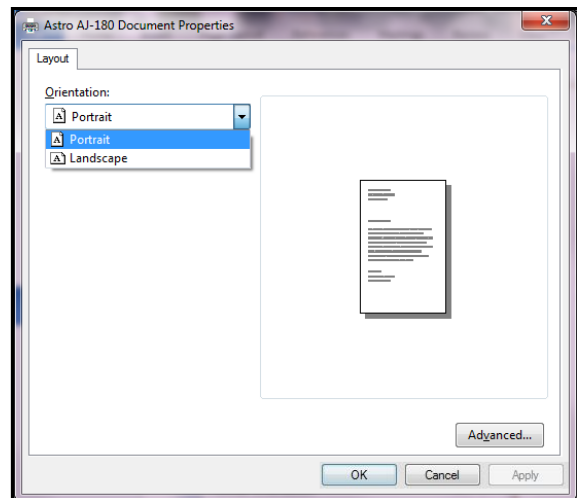

When **Advanced Options window** opens, there are **Paper/Output** and **Document Options** to set up, change, and adjust Printer.

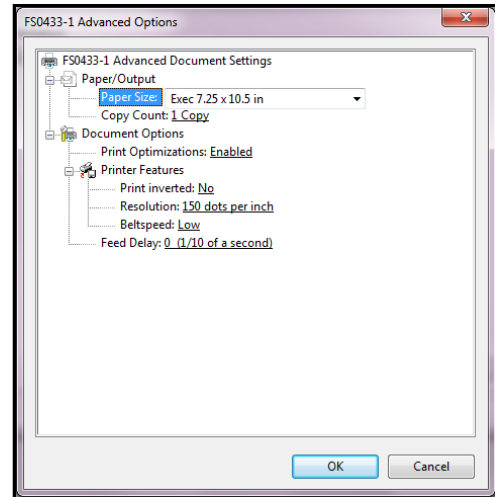

### Paper/Output

**Paper Size:** Select the size of media to be used.  
**Copy Count:** Sets the number of copies to print.

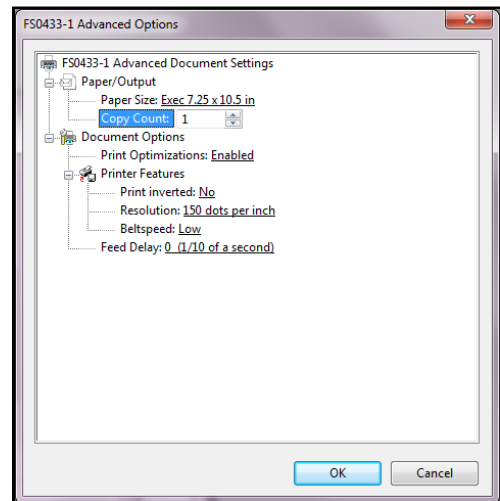
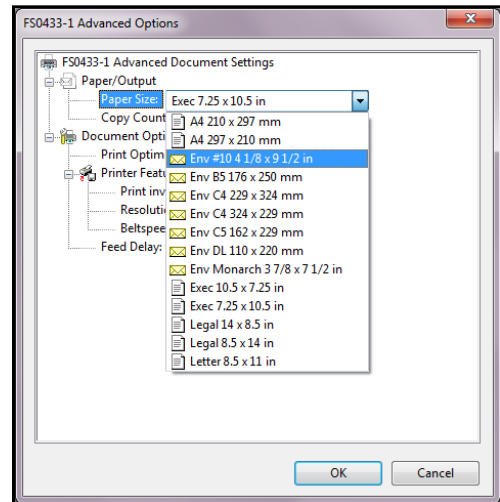

## SECTION 3 OPERATING PRINTER

### Document Options

**Document Options** is used to enable **Print Optimizations**.

**Printer Features:** Set Inverted Printing (*Yes/No*), set the resolution of Printer, set Printer speed, and add a delay to the feed to provide separation between pieces.

**Print Inverted:** In normal operation, printing is read from the operator side of the Printer. It is sometimes necessary to turn the printing direction 180 degrees from the normal direction. This occurs when, due to layout or method of binding, media must be fed in reverse direction.

Selecting and clicking on “**Yes**” permits you to reverse the printing direction 180 degrees. (“*No*” is the default setting.)

**NOTE:** Paper size is always “**Max Print Area**” and Orientation is always “**Portrait**”. Do not change them.

**Resolution:** Sets resolution of print quality. Changing resolution to a higher number (*e.g. 200 DPI to 600 DPI*) increases image quality. **NOTE: Higher resolutions reduce print speed options.**

AstroJet 180	
Resolution	Speeds Available
600 x 150 DPI	Low, Medium, Medium High, High
600 x 200 DPI	Low, Medium and Medium High
600 x 300 DPI	Low and Medium
600 x 600 DPI	Low

**Beltspeed:** Sets initial **Print Speed** for a print job. The speeds available for a particular job are determined by the **Resolution** set for the job.

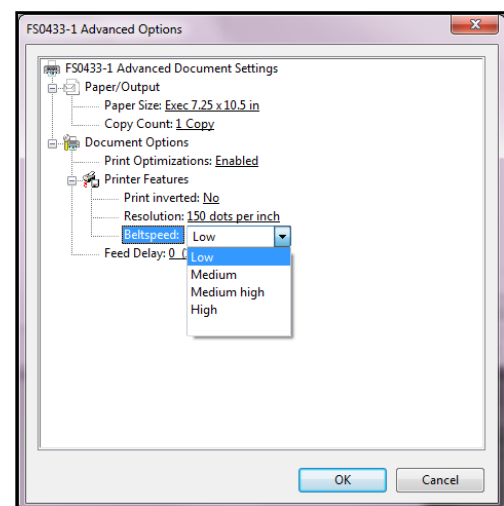
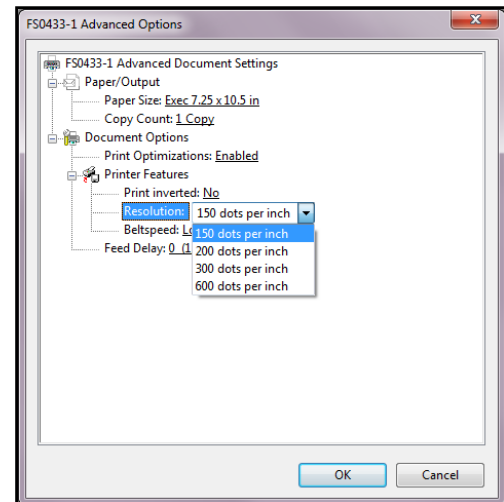
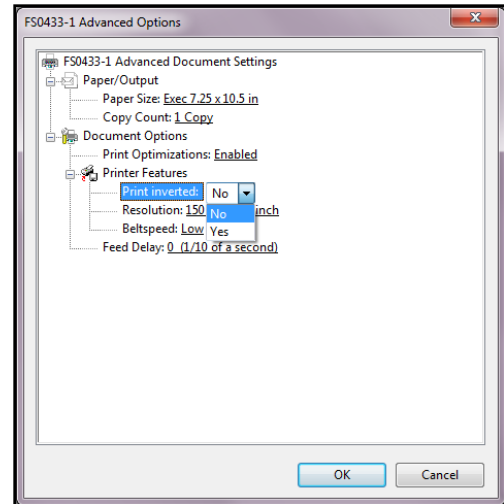

**Feed Delay:** Can be used to put more space between pieces as they are printed. This gives first piece printed more time to dry before next piece is printed.

**Adjustment is made in 0.1-second increments.**

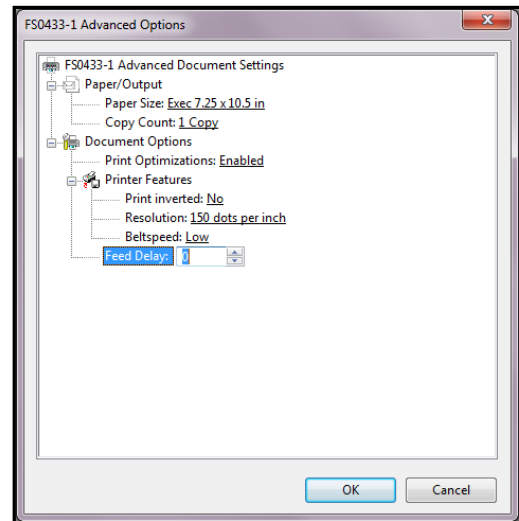

## SECTION 4 - *Maintenance*

This section covers how to care for Ink Cartridges, clear paper jams, replace Sheet Separators, and perform routine maintenance on Printer.

### *Inkjet Cartridge*

Replace Inkjet Cartridges when out of ink, when print quality is poor, or when purging and cleaning have not helped the image quality. Approximate life of Inkjet cartridges, (*based on three lines of 20 characters at 10-point size per address*), is:

600 x 600 DPI	50,000 addresses
300 x 600 DPI	100,000 addresses
200 x 600 DPI	150,000 addresses
150 x 600 DPI	200,000 addresses

NOTE: These figures can vary depending on font selected.

**IMPORTANT! AJ-140/AJ-160/AJ-180 Printers only work with authorized ink cartridges listed on the "Supplies and Optional Hardware" page. Other inks may become available; check with your local Astro dealer. NOTE: Not compatible with refills or other brands.**

#### CAUTION

For continued protection against possible fire, use only genuine HP45 type Ink Cartridges, max. volume 50 ml.

#### MISE EN GUARD

Pour une protection continue contre les risques d'incendie, utilisez uniquement des cartouches d'encre authentiques de type HP45, volume max. 50 ml.

#### CAUTION

Never shake, drop or hit the Cartridge against the palm of your hand or any other hard surface. Shaking the Print Cartridge does not "mix" ink and hitting the Cartridge against a hard surface does not clear Nozzles.

These actions hurt print quality because they allow bubbles to form near the ink firing chambers. These bubbles prevent the nozzles from firing, causing white streaks in the print image.

Replace Inkjet Cartridge:

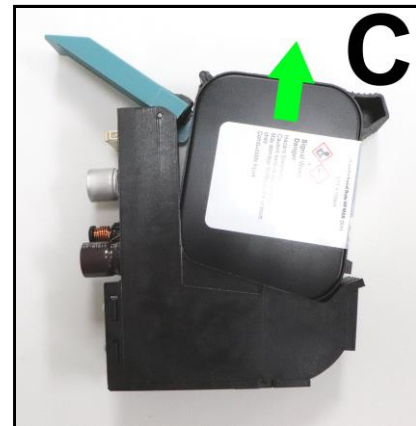
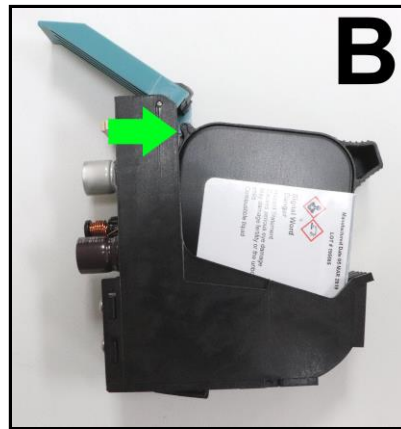
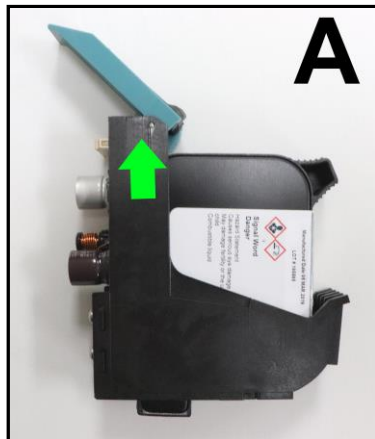

1. Open Latch Lever.
2. [A] Lift the Cartridge straight up until it stops (about 1/4").  
[B] Pivot the Cartridge just enough so the tab on the Cartridge clears, but still touches the edge of the Latch Lever.  
[C] Lift the Cartridge straight up and out of the Holder.  
**NOTE: Be careful not to bend the contact pins in the Holder or damage the surface of the Cartridge Printhead.**



Install New Inkjet Cartridge:

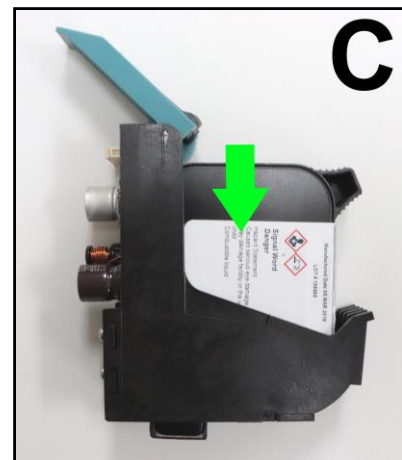
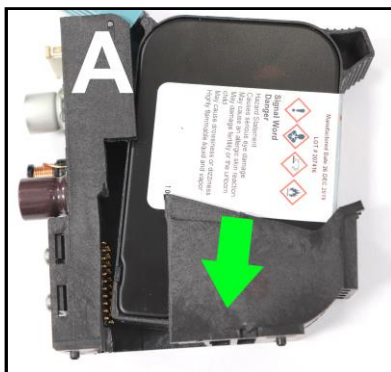

1. Remove new Inkjet Cartridge from packaging. Take care not to touch copper contacts, metal plate, or gold printhead. Remove protective tape from the Printhead.
2. [A] With Cartridge's Printhead pointing down and while keeping the Cartridge lightly in contact with the edge of the Latch Lever: Slide the Cartridge into Holder at as vertical an angle as possible.  
[B] Push straight back toward contacts in the Printhead Holder.  
**NOTE: Be careful not to bend the contact pins in the Holder or to damage the surface of the Cartridge Printhead. (See cutaway images A and X above)**  
[C] Make sure Cartridge is seated in Holder.
3. Close Latch Lever to secure Cartridge. **DO NOT** force Latch Lever into place.
4. Repeat **Steps 1-4** for remaining Cartridges.

## SECTION 4 MAINTENANCE

---

### Storage

**Short-term Storage** – (*less than 2 days or less than 1 day in a hot and dry environment.*)

Leave Cartridge in Printer for short periods of time, 1 day or less.  
Next time Printer is used, Printhead may have to be cleaned and purged.

**Long-term Storage** – (*more than 2 days or more than 1 day in a hot and dry environment.*)

Place Cartridges in a sealable plastic container with a damp sponge or towel to maintain humidity and prevent Printhead from drying out.

When Cartridges are ready to be used again, Printhead may need to be cleaned.

### Disposal

Cartridges may be disposed of in a normal manner.

In case of an ink spill, use soap and water to clean up any problem areas.  
Abrasive soap usually removes ink off of hands.

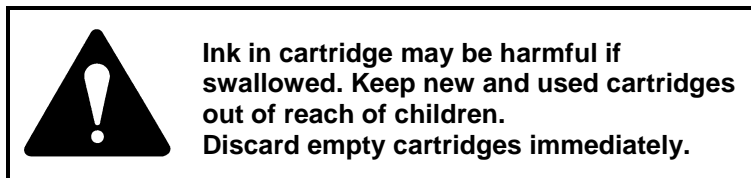

### Cleaning Printhead

Maintain good print quality by keeping Printheads clean. During printing process ink spray, paper fibers, and dust build up on Printheads. This build-up eventually degrades print quality. If you notice problems with print quality, or to just prevent a build-up from occurring, wipe Printhead with a wet fiberless cloth.

<i>Cloth should be:</i>	<i>Cloth should not be:</i>
<ul style="list-style-type: none"><li>✓ Soft</li><li>✓ Fiberless</li><li>✓ Moistened with water (<i>Distilled is best but tap water will work</i>)</li></ul>	<ul style="list-style-type: none"><li>✗ Abrasive</li><li>✗ Made of small fibers</li><li>✗ Dry or contain chemical additives</li></ul>

Wipe slowly across long-axis with Printhead facing down (*as shown*). **DO NOT** apply excessive force, as this could scratch Nozzle area.



## Purging Nozzles

If the Printhead sits inactive for a period of time, ink may dry in the nozzles. Printing may not remove these “ink plugs” from the nozzles. White streaks appear in printed text or graphic. To improve print quality, these ink plugs need to be forced out or purged. A **Purge Print** routine is built into Printer. Access this feature by using the **Quick Menu** key on the Control Panel.

1. Wipe Printhead with a wet cloth as described in “*Cleaning Printhead*” on previous page.
2. With media loaded in the Feeder, press the **Quick Menu** key, then “**Purge Print**” icon. Press “**Print**” to activate the purge. Purge prints an ink pattern at 600 dpi to clear all of the nozzles in all of the ink cartridges. **Repeat if necessary.**
3. Wipe Printhead again with a moist cloth.

**NOTE: For more information, see Troubleshooting Printheads in Section 5 – Troubleshooting.**

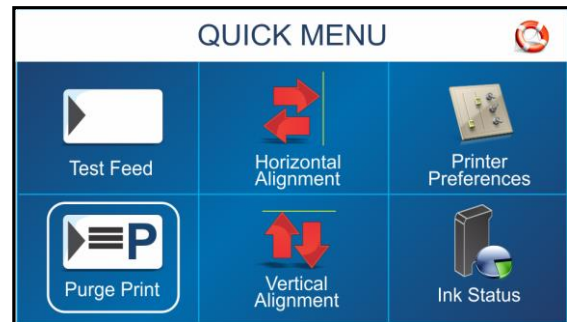

## Jams in Printer

If a jam occurs, **STOP the Printer**. Up to 10 missed addresses can be recovered at Printer Control Panel. (See *Section 3 – Operating Printer “Print Recovery after Jam”*.)

### Some possible reasons for jamming are:

1. Feeding more than one piece of media.
2. Damaged media, such as dog-eared (*turned down corners*).
3. Media that is not stiff enough may not be usable. Media that meets Postal stiffness requirements for automated feeding is acceptable in Printer.
4. Envelopes caught under flap of another envelope or stuck to one another.

### Removing Jammed Media

1. It may be necessary to move one or more Printheads to gain access to jammed media. Take care in removing jammed media to prevent damage to Printheads. Remove all pieces of jammed media from feed path.
2. Follow instructions in *Section 3 – Operating Printer “Print Recovery After Jam”*.

## *Cleaning*

### **WARNING!**

**PRINTER IS A PRECISION MACHINE THAT SHOULD BE CLEANED REGULARLY TO INSURE MANY YEARS OF SERVICE. BEFORE PERFORMING ANY MAINTENANCE, DISCONNECT PRINTER FROM ITS POWER SOURCE!**

Printer must be cleaned regularly of accumulated paper dust and ink. Depending on types of media that are run, paper dust may accumulate within Printer and on Transport. To properly clean Printer, unplug it from power receptacle and remove covers.

- **Internal Areas:** Best cleaned using a vacuum with a soft brush attachment to help loosen dust particles. Take care not to damage PC Boards or electrical wiring.
- **Exterior Areas:** May be cleaned with any standard non-abrasive household cleaner that does not contain plastic-harming solvents.

### **CAUTION**

**NEVER SPRAY OR POUR CLEANERS DIRECTLY ON OR INTO PRINTER. EXCESS LIQUID COULD HARM ELECTRONIC PARTS. ALWAYS DAMPEN A RAG WITH THE CLEANER AND APPLY IT TO THE PARTS TO BE CLEANED.**

## *Feed Rollers and Forwarding Rollers on Printer and Optional Feeder*

Feed and Forwarding Rollers can become glazed with paper lint and ink from media. They should be regularly cleaned with a mild abrasive household cleaner on a damp cloth.

Avoid using solvents on Rubber Rollers.

### *Cleaning Media Sensor*

Periodically check Media Sensor for dust and debris,  
(located under Media Sensor Reflector Plate).

1. Use the Media Thickness Knob to raise the Printhead Carriage Assembly to its highest setting.
2. Remove the Media Sensor Reflector Plate [A].  
(1 screw and nut)
3. Wipe off dust or use canned or compressed air aimed into the Media Sensor port [B] to remove dust and debris from the Sensor. **NOTE: If necessary, wipe the Reflector surface (under the mounting plate) with a clean, lint-free cloth.**

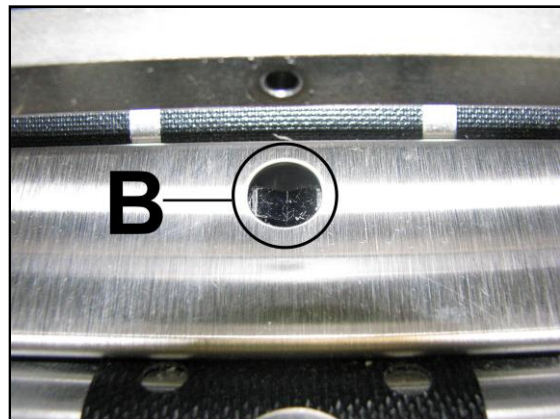
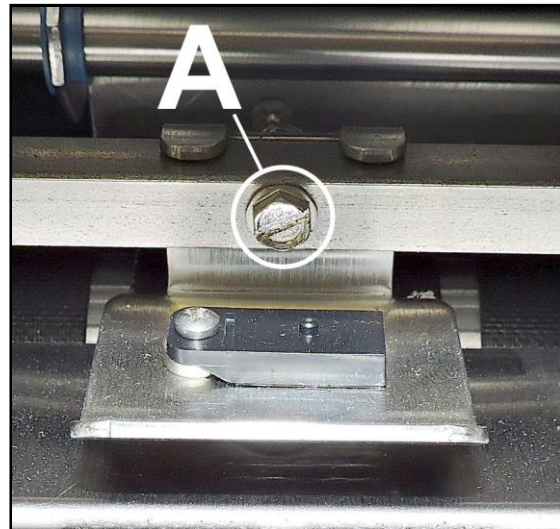

### *Cleaning Touchscreen*

Carefully clean the Touchscreen by wiping with a lint-free cloth and a non-abrasive cleaner made for touchscreens on computers and cell phones. **DO NOT spray cleaner directly on screen, spray on cloth, then clean screen.**



## SECTION 5 – *Troubleshooting Guide*

Troubleshooting Guides are provided to assist you in solving any problems that might occur with Printer or its software. We tried to make them as complete as possible. Best advice we can offer is to make sure that system is setup properly, plugged in, and has an adequate supply of ink before attempting to troubleshoot any problem.



**WARNING!**

**DO NOT REMOVE SIDE COVERS ON PRINTER!  
HIGH VOLTAGES PRESENT BEHIND COVERS!**

### *Inkjet Print Cartridges*

CONDITION	PROBLEM	SOLUTION
<b>Black streaks in text</b> <del>This is a sample of text showing black streaks in the copy.</del>	Lint or paper dust on Printhead.	Clean the Cartridge Nozzles with a clean lint-free cloth moistened with distilled water. Print a <b>Purge Print</b> . See “Section 4 – Maintenance,” <b>Purging Nozzles</b> .
<b>Cartridge will not print</b>	Sheet is blank even after it has gone underneath Cartridge(s).	Check to make sure protective tape is removed from Printhead. Remove and reinsert Ink Cartridge into Carriage Holder. Install new Print Cartridge.
<b>White streaks in text or graphics</b> Michael Jones Astro Machine Corp. 630 Lively Blvd. Elk Grove Village, IL 60007-1234	Lint or dust blocking Printhead holes.  Poor contact between Printhead and Printhead Holder.	Clean the Cartridge Nozzles with a clean lint-free cloth moistened with distilled water. Print a <b>Purge Print</b> . See “Section 4 – Maintenance,” <b>Purging Nozzles</b> . Clean Interconnects. Remove and reinsert Ink Cartridge into Holder. Insert new Print Cartridge.



*Printer*

CONDITION	PROBLEM	SOLUTION
<b>Extra lines; losing data</b>	Database problem.	Check data in database program.
<b>Improper output</b> <i>(address information out of order, misfeeding, etc.)</i>	Wrong Interface settings. Static electricity. Dirty Media Sensor.	Check software or database on PC. Turn Printer OFF/ON. Clean Media Sensor.
	Paper jam.  Double feeding. Media is curled or bent. Media is too thin.	Clear media from feeder and/or print transport area. Adjust Sheet Separators on Feeder. Uncurl media. <b>Minimum media thickness:</b> at least 0.008" (0.2 mm) thick.
	No gap detected between pieces. Media size does not match the page size specified by the job.	Clear media from feeder and/or print transport area.  Use <b>Reprint</b> (on <i>Quick Menu</i> screen) to retrieve/restore missing or misprinted pages in the print job.
<b>No communication</b>	Improper cabling/connector.  Unit not receiving power.	Use proper cable (see <i>Operator Manual</i> ). Check plug connections, ON/OFF Switch and Fuse on Back Panel (see <i>Operator Manual</i> ).
<b>Not printing on media</b>	Media not positioned properly.	Adjust Printhead vertically. Adjust margin setting in layout software.
<b>Print too light or missing character dots</b>	Clogged or dirty Printheads. Running out of ink.	Purge or clean Ink Cartridges. Replace Ink Cartridges.
<b>Blurry address</b> 	Image is not sharp.	Printhead gap too high. Adjust Printhead closer to media.
<b>Split line of type</b> <b>Astro Machine Corp.</b> <b>630 Lively Blvd.</b> <b>Elk Grove Village, IL 60007</b>	Line of type is placed across Printheads.	Reposition text in layout so that it does not print across two Printheads. Adjust positioning of the two Printheads in relationship to each other using <b>Head Alignment</b> in <b>Quick Menu</b> on Control Panel.
<b>Uneven split line of type</b> <b>Astro Machine Corp.</b> <b>630 Lively Blvd.</b> <b>Elk Grove Village, IL 60007</b>	Some, but not all of a line of type across two Printheads matches up.	Reposition text in layout so it does not print across two Printheads. Check Sheet Separator adjustment. Separators should just touch media. Check Printhead height. If Printhead is set too high, media slips as it passes under Heads.

**SECTION 5  
TROUBLESHOOTING**

***Touchscreen Messages***

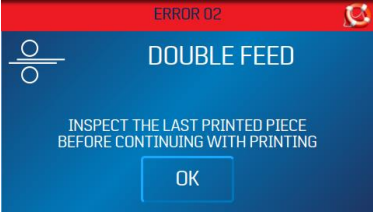
The Touchscreen will display messages to alert you to problems or to indicate a process is finished.

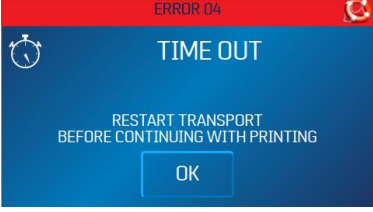
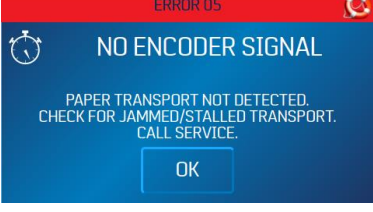
SCREEN MESSAGE	PROBLEM	SOLUTION
	<p>No gap detected between pieces.</p> <p>Media size does not match the page size specified by the job.</p>	<p>Clear media from feeder and/or print transport area.</p> <p>Use <b>Reprint</b> (on <i>Quick Menu screen</i>) to retrieve/restore any missing or misprinted pages in the print job.</p> <p>Press <b>OK</b> to continue.</p>
	<p>No media in Feeder/Hopper.</p>	<p>Reload media.</p> <p>Press <b>OK</b> to continue.</p>
	<p>Printer operation has timed out or Printer was paused too long.</p>	<p>Check Printer.</p> <p>Press <b>OK</b> to continue.</p>
	<p>Printer Motor has stopped.</p> <p>Wire Harness connection is loose or broken.</p> <p>Encoder Belt worn or broken.</p> <p>Encoder Sensor not working.</p>	<p>Check Printer Motor.</p> <p>Check <b>J5</b> connector on I/O Board.</p> <p>Check Encoder Belt.</p> <p>Check Encoder Sensor.</p>

## APPENDIX A – Specifications

<b>PRINT TECHNOLOGY</b>	8-Head Inkjet, proprietary High Capacity Inkjet Cartridges
<b>ADDRESS SPEED</b>	Up to 34,000/hour (#10 Envelopes)
<b>PRINT QUALITY/SPEED</b> (Dots Per Inch)	<b>1-High Quality</b> 600 x 600 DPI (25 in. /sec.; 125 ft. /min.; 38 m/min.) <b>2-Standard Quality</b> 600 x 300 DPI (50 in. /sec.; 250 ft. /min.; 76 m/min.) <b>3-Letter Quality</b> 600 x 200 DPI (75 in. /sec.; 375 ft. /min.; 114 m/min.) <b>4-Draft Quality</b> 600 x 150 DPI (95 in. /sec.; 475 ft. /min.; 145 m/min.)
<b>IMAGE AREA</b>	4" x 15" (101.6 mm x 381 mm)
<b>PRINT ORIENTATION</b>	<b>AJ-180:</b> Left-to-Right <b>AJ-180R:</b> Right-to-Left
<b>FONTS</b>	All TrueType fonts available on PC
<b>PRINTS</b>	Prints graphics, logos, and barcodes
<b>MEDIA SIZE</b> (Minimum to Maximum)	<b>Length:</b> 5" to 15" (127 mm x 381 mm) <b>Width:</b> 3" to 14" (76.2 mm x 355.6 mm) (Printable: 12"/304.8 mm)
<b>MEDIA THICKNESS</b>	<b>Minimum:</b> 0.008" (0.2 mm) <b>Maximum:</b> 0.5" (12 mm)
<b>PROCESSOR</b>	600 MHz Dual-core ARM Cortex-A9 MP Core
<b>MEMORY</b>	1 GB of DDR3-1600Mhz SDRAM 8 GB ( <i>default</i> ) microSD. Not externally accessible
<b>PRINT COLORS</b>	Proprietary water-based inks in Inkjet Cartridges
<b>INK</b>	Water-based, may require drying assistance for coated stock
<b>INK MONITOR</b>	Visible on Touchscreen Display
<b>SOFTWARE</b>	Windows™ compatible Printer Drivers for Windows™ operating systems
<b>DIAGNOSTICS</b>	Resident in firmware
<b>FIRMWARE UPDATE</b>	Flash PROM update
<b>PC INTERFACE</b>	Ethernet Port (10/100/1000Mhz) USB 3.1 Port ( <i>also supports USB 2.0</i> ) Wireless with external wireless to USB adapter
<b>COUNTERS</b>	Lifetime Piece Counter, Session Counter, Jobs Counter
<b>DUTY CYCLE</b>	75 million addresses total or 1,250,000 per month over a 5-year life cycle.
<b>DIMENSIONS</b>	12.125" H x 33.5" L x 25.25" W (30.8 cm H x 85 cm L x 64.2 cm W)
<b>WEIGHT</b>	96 lbs. (43.5 kg)
<b>ELECTRICAL</b>	<b>Switchable:</b> 115VAC or 240VAC, 50/60 Hz
<b>OPTIONS</b>	<b>AJ-180:</b> Left-to-Right or <b>AJ-180R:</b> Right-to-Left operation, Printer Stand, Conveyor, Conveyor Drop Tray and Feeders

All Specifications Subject To Change Without Notice



### ***Regulatory Compliance***

**FCC:** "This device complies with Part 15 of the FCC Rules.

Operation is subject to the following conditions:

1. This device may not cause harmful interference.
2. This device must accept any interference received including interference that may cause undesired operation."

This Class A digital apparatus complies with Canadian ICES-003.

Cet appareil numérique de la classe A est conforme à la norme NMB-003 du Canada.

## APPENDIX B – *Supplies and Optional Hardware*

The following supply items and optional hardware are available from your Astro Machine Dealer:

### *Supplies*

**IMPORTANT! AJ-140/AJ-160/AJ-180 Printers only work with the ink cartridges listed below. Other inks may become available; check with your local Astro dealer.**

**NOTE: Not compatible with refills or other brands.**

INK TYPE	DESCRIPTION	PART NO.
<b>AMC-MAX3</b>	High performance, quick-drying, water/solvent-based black ink for aqueous varnished media, Tyvek, PVC and more.	123-3087
<b>AMC-Superfast</b>	General purpose, quick-drying, dye-based black ink for uncoated and some coated media.	123-3088
<b>AMC-Complete</b>	All-purpose black dye/pigmented hybrid-based ink for a wide range of coated and uncoated media with dark black print.	123-3188
<b>AMC-Blue</b>	Spot color blue pigmented hybrid-based ink for a variety of coated and uncoated media.	123-3089
<b>AMC-Red</b>	Spot color red pigmented hybrid-based ink for a variety of coated and uncoated media.	123-3090
<b>AMC-Green</b>	Spot color green pigmented hybrid-based ink for a variety of coated and uncoated media.	123-3179
<b>AMC-Security</b>	"Invisible" ink is visible under UV light. Works with aqueous varnished media, Tyvek, PVC and more.	123-3203
<b>AMC-Solvent</b>	High performance black solvent-based ink for UV-coated and nonporous media including plastics, PVC, aluminum and more.	123-3085
<b>AMC-Bear</b>	Economical dark gray solvent-based ink for nonporous media and coated or varnished stock.	123-3086

### *Optional Hardware*

DESCRIPTION	PART NO.
<b>Vacuum Feeder</b>	ASF-3000
<b>Friction Feeder</b> <i>(Includes Feeder Stand below)</i>	FF-14
<b>Conveyor</b>	CDM-700
<b>Drop Tray:</b> <b>For Left-to-Right Printer</b> <b>For Right-to-Left Printer</b>	DTM-250 DTM-255
<b>Friction Feeder Stand Assembly</b>	97-620-32

# INDEX

## A

Adjustment Knob, Media Thickness ..... 1

**Alphanumeric Keyboard**..... 20

Antenna, Wi-Fi ..... 6

Auto/Manual Switch, Feeder ..... 4

## B

Batch Counter, Feeder ..... 4

Belts, Transport ..... 2

## C

Calibration, Touchscreen ..... 31

Carriage, Printhead ..... 1

Cartridge Initialize Button ..... 31

### Cartridges

Inkjet ..... 10, 38

Printhead ..... 40

**Cleaning**..... 42

Feed Rollers ..... 42

Forwarding Rollers ..... 42

Media Sensor ..... 43

Printhead ..... 40

Touchscreen ..... 43

Compliance, Regulatory ..... 48

### Connect

Feeder ..... 6

Feeder, Optional ..... 9

Printer ..... 6

To Computer ..... 6

To Network ..... 6

Wi-Fi Antenna ..... 6

Wi-Fi Port ..... 6

Contents of Packaging ..... 5

Continuous Feed Switch, Feeder ..... 4

### Control Panel

Feeder ON/OFF Key ..... 1, 3

Power OFF/Reset Key ..... 1

Power OFF/Restart Key ..... 3

Printer ..... 3

Quick Menu Key ..... 1, 3, 33

Shutdown Printer Buttons ..... 31

Touchscreen ..... 1, 3

Transport ON/OFF Key ..... 1, 3

Transport Pass-Through Button ..... 32

**Control Panel, Feeder**..... 4

Auto/Manual Switch ..... 4

Batch Counter ..... 4

Continuous Feed Switch ..... 4

Single Feed Switch ..... 4

Speed Control ..... 4

Cover, Top ..... 1

## D

Date and Time ..... 30

Diagnostics ..... 29

### Display

Cleaning ..... 43

Control Panel ..... 1, 3

Using ..... 19

Disposal, Inkjet Cartridges ..... 40

## E

Ethernet Port ..... 2, 6

Exit Guides, Media ..... 1

## F

Factory Default ..... 26

FCC Compliance ..... 48

**Feeder** ..... 4

Assembly ..... 9

Cleaning Rollers ..... 42

Connect ..... 6

Connect to Printer ..... 9

Control Panel ..... 4

Fuse Holder ..... 4

Interface Connector ..... 4

ON/OFF Switch ..... 4

Power Receptacle ..... 4

Set-Up ..... 12

Feeder ON/OFF Key ..... 1, 3

Firmware Updates ..... 32

Fuse ..... 2

Fuse Holder, Feeder ..... 4

## G

### Guides

Media Feed ..... 2

Media Side ..... 2

## H

Hardware, Optional ..... 49

Holder, Printhead ..... 1

Horizontal Alignment, Printhead ..... 27

## I

Indicator Light, Power ..... 1

Ink Estimator ..... 28

Ink Status ..... 28

Ink Type Screen ..... 24

### Inkjet Cartridges

Disposal ..... 40

Install ..... 10

Maintenance ..... 38

Replace ..... 39

Storage ..... 40

Troubleshooting ..... 44

<b>Install</b>		Control Panel Touchscreen.....	1
Inkjet Cartridges .....	10	Ethernet Port.....	2
Printer .....	5	Firmware Updates.....	32
Printer Driver.....	15	Fuse.....	2
Printer Update Utility Software .....	17	Install .....	5
<b>Interface Connector</b>		Interface Connector, Printer/Feeder.....	2
Feeder .....	4	Jams .....	41
Printer/Feeder .....	2	Main Power Switch .....	2
<b>J</b>		Maintenance.....	38
Jams, Printer .....	41	Media Exit Guides .....	1
<b>L</b>		Media Feed Guides .....	2
Language, Select.....	26	Media Retainer Assembly.....	2
Location, Choose .....	5	Media Sensor .....	1
<b>M</b>		Media Side Guides.....	2
Main Menu .....	21	Media Thickness Adjustment Knob .....	1
Main Power Switch .....	2	Network Port.....	2
<b>Maintenance</b> .....	38	Network Settings .....	29
Cleaning.....	42	Operating .....	19
Inkjet Cartridges .....	38	Package Contents.....	5
Printer Jams .....	41	Power Indicator.....	1
Printhead.....	40	Power Receptacle .....	2
Media Exit Guides.....	1	Preferences .....	25
Media Feed Guides .....	2	Set-up Screen.....	24
Media Retainer Assembly.....	2	Specifications.....	47
<b>Media Sensor</b>		Supplies & Hardware.....	49
Cleaning.....	43	Time Server .....	30
Printer .....	1	Tools .....	27
Media Side Guides.....	2	Top Cover.....	1
Media Thickness Adjustment Knob .....	1	Transport Belts .....	2
Media, Adjust Printer .....	11	Troubleshooting .....	44
Messages, Touchscreen .....	46	Update Utility, Install .....	17
<b>N</b>		USB Port.....	2
Network Port .....	2, 6	Wi-Fi Port.....	2
Network Settings .....	29	Wi-Fi Set-up .....	30
Nozzles, Purging.....	41	Wireless Status .....	29
<b>O</b>		<b>Printer Driver</b>	
ON/OFF Switch, Feeder .....	4	Install .....	15
Operating Printer .....	19	Properties.....	34
<b>P</b>		<b>Printhead</b>	
Pass-Through Button .....	32	Carriage .....	1
Port Reset Button.....	31	Cleaning.....	40
Power Button .....	31	Holder.....	1
Power Indicator Light.....	1	Purging Inkjet Nozzles .....	41
Power OFF/Reset Key .....	1	<b>Q</b>	
Power OFF/Restart Key.....	3	Quick Menu Key .....	1, 3, 33
Power Receptacle .....	2	<b>R</b>	
Power Receptacle, Feeder.....	4	Read and Print, Touchscreen .....	31
Print Image Screen.....	22	Regulatory Compliance .....	48
<b>Printer</b>		<b>Remove/Replace</b>	
Adjust to Media .....	11	Inkjet Cartridge.....	39
Choose Location .....	5	Jams, Media .....	41
Cleaning.....	42	Restart Button.....	8, 31
Connect.....	6	Rollers, Cleaning .....	42
Control Panel.....	3		
Control Panel Keys.....	1		

## INDEX

---

### S

Sensor, Media .....1

#### Set-Up

Feeder .....12  
Network .....29  
Printer .....24  
Wi-Fi.....30

Shutdown Button .....7, 31

Single Feed Switch, Feeder .....4

Sleep Now Button.....31

Software, Printer Update Utility .....17

Specifications, Printer .....47

Speed Control, Feeder .....4

Storage, Inkjet Cartridges .....40

Supplies .....49

#### Switch

Main Power .....7  
On/Off.....7

### T

Tools, Printer .....27

Top Cover .....1

#### Touchscreen

**Alphanumeric Keyboard**.....20  
Calibration .....31  
Cleaning .....43  
Control Panel .....1, 3  
Diagnostics .....29  
Horizontal Alignment, Printhead .....27  
Ink Estimator .....28  
Ink Status .....28  
Ink Type.....24  
Main Menu .....21  
Messages.....46  
Print Image Screen.....22  
Printer Preferences.....25  
Printer Set-up Screen .....24  
Printer Tools .....27  
Read and Print .....31  
Select Language.....26  
Using.....19  
Vertical Alignment, Printhead .....27

Transport Belts .....2

Transport ON/OFF Key .....1, 3

Transport Pass-Through Button.....32

#### Troubleshooting

Inkjet Cartridges .....44  
Printer .....45  
Touchscreen Messages .....46

### U

Update Utility, Install Printer .....17

Update, Firmware .....32

USB Disconnect Button.....31

USB Port.....2, 6

Using Touchscreens.....19

### V

Vertical Alignment, Printhead .....27

### W

#### Wi-Fi

Antenna.....6

Port .....2, 6

Set-Up.....30

Wireless Status .....29

---

---

---

Copyright © 2020 ASTRO MACHINE CORP.  
Elk Grove Village, IL 60007  
11/19/2020  
Part Number: **200-AJ180**

---