



ASTROJET™ 160 PRINTER



OPERATOR MANUAL

Astro Machine Corp.
630 Lively Blvd.
Elk Grove Village, IL 60007
Phone: (847) 364-6363
Fax: (847) 364-9898
www.astromachine.com

SAFETY PRECAUTIONS

THIS EQUIPMENT PRESENTS NO PROBLEM WHEN USED PROPERLY. OBSERVE SAFETY RULES WHEN OPERATING THE PRINTER. BEFORE USING PRINTER, READ THIS MANUAL CAREFULLY AND FOLLOW RECOMMENDED PROCEDURES, SAFETY WARNINGS, AND INSTRUCTIONS:

WARNING:

Hazardous Moving Parts. Keep Fingers and Other Body Parts Away.

ATTENTION:

Pièces mobiles dangereuses. Veuillez que les doigts et les autres parties du corps sont à l'écart.

CAUTION

Double pole/neutral fusing. For continued protection against risk of fire, replace only with same type and rating of fuse.

MISE EN GUARD

Fusible bipolaire / neutre. Pour protéger contre le risque d'incendie, remplacez avec le même type et la même classe de fusible.

- ✓ Avoid touching moving parts or materials while machine is in use. Before clearing a jam, be sure machine mechanisms come to a stop.
- ✓ Always turn machine off before making adjustments, cleaning machine, or performing any maintenance covered in this manual.
- ✓ Power cord is supplied with machine. Plug it into a properly grounded wall, easily accessible outlet located near machine. Failure to properly ground machine can result in severe personal injury and/or fire.
- ✓ Power cord and wall plug are primary means of disconnecting machine from power supply.
- ✓ **DO NOT** use an adapter plug on line cord or wall outlet or remove ground pin from line cord. Avoid using wall outlets that are controlled by wall switches, or shared with other equipment.
- ✓ **DO NOT** route power cord over sharp edges or trap it between furniture. Make sure there is no strain on power cord caused by jamming it between equipment, walls or furniture.
- ✓ **DO NOT** remove covers. Covers enclose hazardous parts that should only be accessed by a qualified service representative. Report any cover damage to your service representative.
- ✓ This machine requires periodic maintenance. Contact your authorized service representative for required service schedules.
- ✓ To prevent overheating, do not cover vent openings.
- ✓ Use this equipment only for its intended purpose.

In addition, follow any specific occupational safety and health standards for your workplace or area.

This manual is intended solely for the use and information of Astro Machine Corp., its designated agents, customers, and their employees. The information in this guide was obtained from several different sources that are deemed reliable by all industry standards. To the best of our knowledge, that information is accurate in all respects. However, neither Astro Machine Corp. nor any of its agents or employees shall be responsible for any inaccuracies contained herein.

AstroJet™ is a registered trademark of Astro Machine Corp.
Windows is a registered trademark of Microsoft Corporation.
All other trademarks are the property of their respective holders.

All rights reserved. No part of this book may be reproduced or transmitted in any form or by any means, electronic or mechanical, including photocopying, recording, or any information storage and retrieval system, without permission in writing from the publisher.

Table of Contents

SECTION 1 – <i>Getting Acquainted</i>	1
SECTION 2 – <i>Install Printer</i>	5
Before using Printer:	5
Contents of Packaging	5
Assemble Printer	5
Install Side Guides	6
Install Rear Media Support and Guide	6
Connect Printer	7
Install Inkjet Cartridges	10
Setting up Feed	11
Install Printer Driver	13
Install Printer Update Utility	15
SECTION 3 – <i>Operating Printer</i>	17
Using the Touchscreen	17
Power Button	29
Firmware Updates	29
Quick Menu	30
Printer Driver Properties	31
SECTION 4 - <i>Maintenance</i>	35
Inkjet Cartridge	35
Cleaning Printhead	37
Purging Nozzles	38
Jams in Printer	38
Replace Sheet Separators	38
Cleaning	39
Feed Rollers and Forwarding Rollers	39
Cleaning Media Sensor	39
Cleaning Touchscreen	39
SECTION 5 – <i>Troubleshooting Guide</i>	40
Inkjet Print Cartridges	40
Printer	41
Touchscreen Messages	42
APPENDIX A – <i>Specifications</i>	43
Regulatory Compliance	44
APPENDIX B – <i>Supplies and Optional Hardware</i>	45
Supplies	45
Optional Hardware	45
INDEX	46

SECTION 1 – *Getting Acquainted*

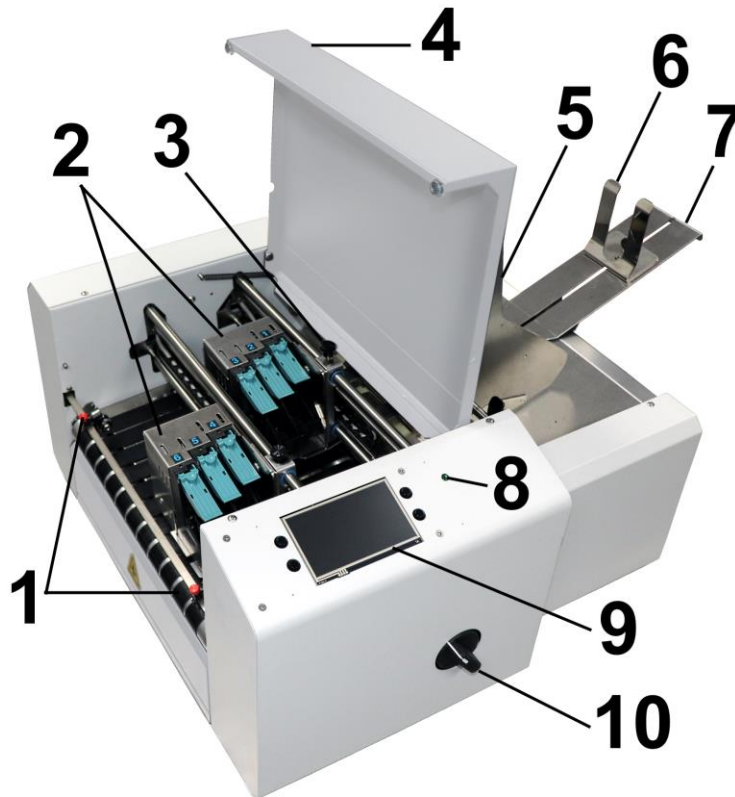

Operator View

1.	EXIT GUIDES – Help media to exit Printer.
2.	PRINthead ASSEMBLY – Has six Printheads arranged on two rails and can print an image up to 3" wide.
3.	MEDIA SENSOR – Senses media as it enters the Printhead area. Located behind Printhead Assembly.
4.	TOP SAFETY COVER – Encloses the Printheads.
5.	MEDIA SIDE GUIDES – Position media in Printer.
6.	REAR MEDIA GUIDE – Holds media against Front Plate.
7.	REAR MEDIA SUPPORT – Supports media while it is being fed.
8.	POWER INDICATOR LIGHT – Shows that main power is ON.
9.	CONTROL PANEL TOUCHSCREEN – Touchscreen allows access to Printer menus and controls to set up and operate the Printer. Four Control Keys to access or operate Quick Menu, Power Off/Reset, Transport ON/OFF, Feeder ON/OFF .
10.	MEDIA THICKNESS ADJUSTMENT KNOB – Adjusts height of Printheads to compensate for different media thicknesses. NOTE: Always raise Printheads to their uppermost position when storing Printer.

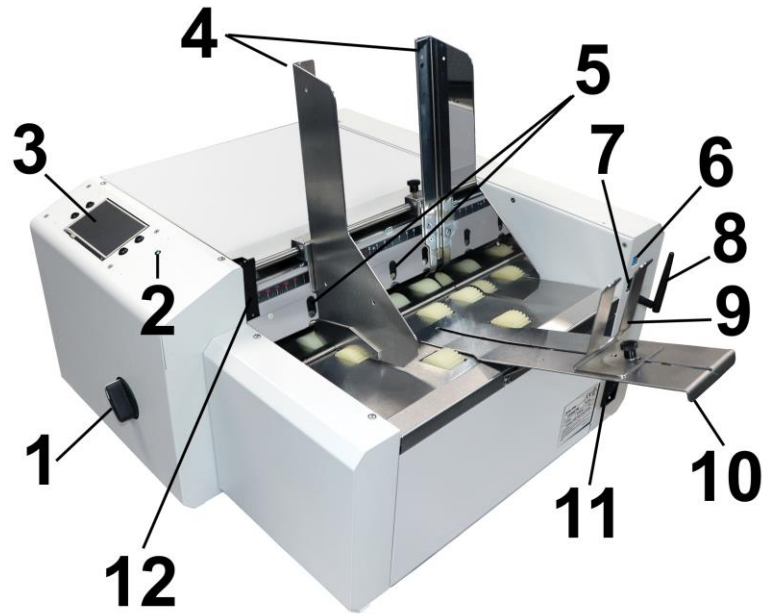

Rear View

1.	MEDIA THICKNESS ADJUSTMENT KNOB – Adjusts height of Printheads to compensate for different media thicknesses.
2.	POWER INDICATOR LIGHT – Shows that main power is ON.
3.	CONTROL PANEL TOUCHSCREEN – Touchscreen allows access to Printer menus and controls to set up and operate the Printer. Four Control Keys to access or operate Quick Menu, Power Off/Reset, Online/Offline, Pause/Print .
4.	MEDIA SIDE GUIDES – Position media in Printer.
5.	SHEET SEPARATORS – Adjustable to ensure proper tension with Feed Rollers for different media thicknesses. Four Separators to handle different media widths.
6.	USB 3.1 PORT – Connects Printer to your computer. <i>(Also supports USB 2.0)</i>
7.	ETHERNET PORT – Connects Printer to a network.
8.	WI-FI PORT – Connect Wi-Fi antenna <i>(included)</i> to monitor or operate the Printer wirelessly through your network.
9.	REAR MEDIA GUIDE – Holds media against Front Plate. <i>(Narrow and Wide Guides included.)</i>
10.	REAR MEDIA SUPPORT – Supports media while it is being fed.
11.	MAIN POWER SWITCH, FUSE AND POWER RECEPTACLE – Power cord plugs in here. The window panel shows what voltage the Printer is set for: 115V or 220V. Switch turns Printer ON and OFF. Fuse protects Motor from overloads. CAUTION: Double pole/neutral fusing. For continued protection against risk of fire, replace only with same type and rating of fuse. MISE EN GARDE: Fusible bipolaire/neuter. Pour protéger contre le risque d'incendie, remplacez avec le même type et la même classe de fusible.
12.	SEPARATOR LOCKING LEVER – Unlocks/locks Sheet Separators to adjust Separators for different types of media.

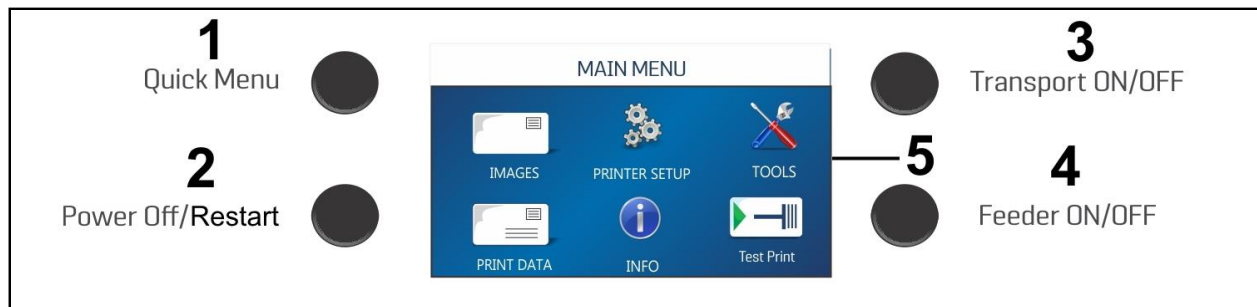

Control Panel

1.	<p>QUICK MENU KEY – Allows quick access to often-used Printer functions without having to scroll through a number of screens. Test Feed/Reprint, Horizontal and Vertical Alignment, Printer Preferences, Purge Print, and Ink Status.</p> <p>Press to open. Press Quick Menu key again to exit screen.</p>
2.	<p>POWER OFF/RESTART/UTILITY KEY – The Shutdown Printer screen opens with 6 button options: Restart, Shutdown, USB Disconnect, Sleep Now, Port Reset and Cartridge Initialize. Shutdown closes Printer functions safely before shutting off Printer power with the Main Power Switch.</p>
3.	<p>TRANSPORT ON/OFF KEY – Turns the Transport Motor ON and OFF. Press to turn Transport OFF. Also used to temporarily run the Transport to clear media from under the Printheads.</p>
4.	<p>FEEDER ON/OFF KEY – Turns the Feeder ON and OFF. Provides a quick way to print and pause a job at the Printer without using the Touchscreen or computer. Press to start printing. Press to pause a running job. Press key again to resume printing. NOTE: After pausing a job, pressing this key starts both Feeder and Transport.</p>
5.	<p>CONTROL PANEL TOUCHSCREEN – Use the Control Panel Buttons to open certain screens and/or use the Touchscreen arrow and screen icons to operate the Printer and set and adjust Printer settings and functions. You can also check Printer status and error messages.</p>

NOTE: A complete description of the functions and operation of the Touchscreen can be found in [Section 3 – Operating the Printer](#).

SECTION 2 – *Install Printer*

Before using Printer:

- Choose a location for Printer
- Assemble Printer
- Plug in Printer and connect it to computer
- Install Inkjet Cartridges
- Set up feed on Printer
- Install Printer Driver software on computer



Choose a Location

Printer should be placed on a sturdy worktable or cabinet at least 12" (30.5 cm) from any walls. Protect Printer from excessive heat, dust, and moisture – avoid placing it in direct sunlight.

Contents of Packaging

1.	AJ-160 Printer
2.	Power Cord
3.	Wi-Fi Antenna
4.	Side Guides
5.	Rear Media Support and Narrow and Wide Rear Media Guides
6.	Quick Start Guide
7.	USB Flash Drive (<i>Includes Printer Driver, Operator Manual</i>)
8.	USB Cable
9.	Network Cable

Assemble Printer

Tools required: Standard #2 Phillips head screwdriver.

Install Side Guides

1. Remove two screws [A] from each Side Guide Block.
2. Align Side Guide screw holes with holes in Side Guide Blocks.
3. Insert screws removed in **Step 1**. Tighten so Guides are firmly attached to Side Guide Blocks.

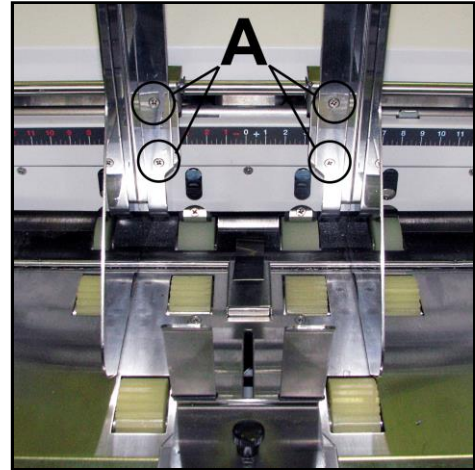

Install Rear Media Support and Guide

1. **Install Rear Media Support.** Use two screws [A] (*included*) to attach the Rear Media Support to the Rear Center Plate.
2. Install two screws [B] into top of Rear Center Plate.
3. **Install Rear Media Guide.** Insert Adjusting Knob [C] through Rear Media Guide and Rear Media Support. Screw into rectangular washer [D].

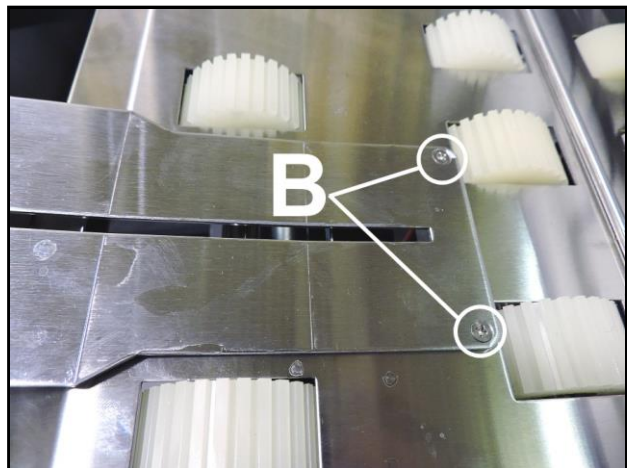
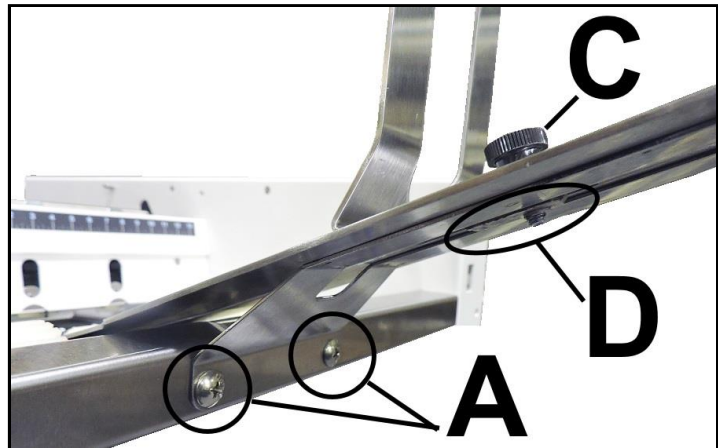

Connect Printer

Plugging in Printer

Make sure Printer's Main Power Switch is turned OFF.

1. Check that the Printer is set for the power to be used (115V or 220V) [A].
2. Connect one end of the power cord to the rear receptacle on the Printer.
3. Plug other end into a 115-220 Volt AC (depending on Printer voltage), 50/60 Hz. grounded outlet.

CAUTION
<p>DO NOT USE ADAPTER PLUGS OR EXTENSION CORDS TO CONNECT PRINTER TO WALL OUTLET.</p> <p>DO NOT USE WITH OUTLETS CONTROLLED BY WALL SWITCHES.</p> <p>DO NOT USE WITH OUTLETS THAT SHARE THE SAME CIRCUIT WITH LARGE ELECTRICAL MACHINES OR APPLIANCES.</p>



Connect to Computer or Network

USB 3.1 Port: Plug USB cable into connector [1]. Cable used to connect Printer to computer must not exceed 6 feet long.

Ethernet (Network) Port: Plug network Ethernet cable into Ethernet connector [2].

Wi-Fi Port: Connect Wi-Fi antenna (included) to this port [3] for wireless Printer monitoring or operation through your network.

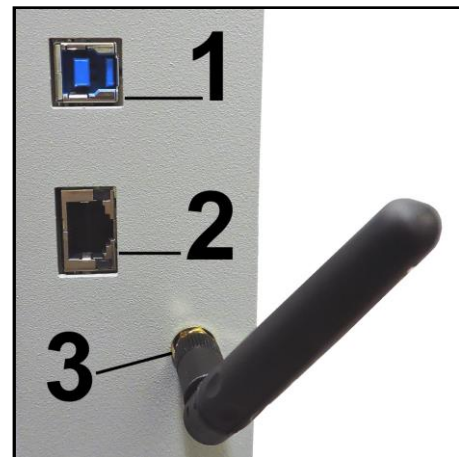

Turning Power ON and OFF

IMPORTANT!

CLOSE ALL COVERS AND DOORS BEFORE STARTING OR POWERING DOWN THE PRINTER.

Powering Up Printer:

1. Press the **Main Power Switch** located on the Feed End of the Printer. The Printer will start up.



Powering Down Printer:

WHENEVER POWERING DOWN PRINTER, ALWAYS:

1. Close all covers.
2. Tap the **Power Off/Restart Button** on the **Control Panel**. The **Shutdown Printer** screen opens. Press the "Shutdown" button.
3. Wait for the Printer to stop processing. Watch the Touchscreen [A and B]. **DO NOT touch the Main Power Switch until the Touchscreen indicates it is safe to do so.**
4. Press the **Main Power Switch** to turn Printer power OFF.



Using the Restart Button:

1. Close all covers.
2. Tap the **Power Off/Restart Button** on the **Control Panel**. The **Shutdown Printer** screen opens. Press the "**Restart**" button.
3. Wait for the Printer to stop processing. Watch the Touchscreen [A]. **DO NOT touch the Main Power Switch; the Printer will come on automatically.**



SECTION 2 INSTALLING PRINTER

Install Inkjet Cartridges

Printer uses 6 proprietary Inkjet Cartridges. To install Cartridges:

IMPORTANT! AJ-140/AJ-160/AJ-180 Printers only work with authorized ink cartridges listed on the "Supplies and Optional Hardware" page. Other inks may become available; check with your local Astro dealer. **NOTE:** Not compatible with refills or other brands.

CAUTION

For continued protection against possible fire, use only genuine HP45 type Ink Cartridges, max. volume 50 ml.

MISE EN GARDE

Pour une protection continue contre les risques d'incendie, utilisez uniquement des cartouches d'encre authentiques de type HP45, volume max. 50 ml.

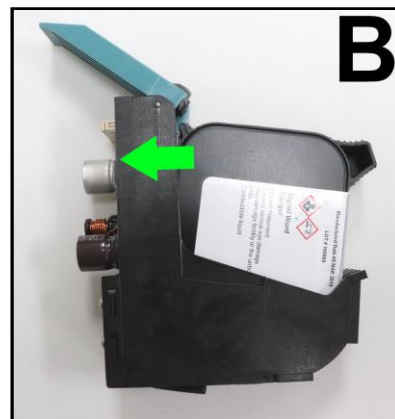
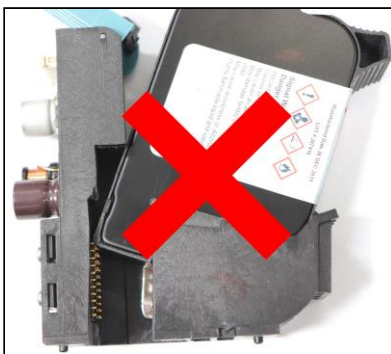
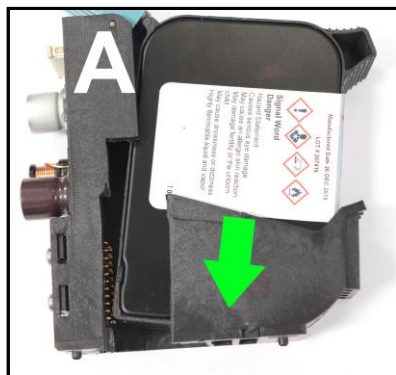

1. Remove new Inkjet Cartridge from packaging. Take care not to touch copper contacts, metal plate, or gold printhead. Remove protective tape from the Printhead.
2. [A] With Cartridge's Printhead pointing down and while keeping the Cartridge lightly in contact with the edge of the Latch Lever: Slide the Cartridge into Holder at as vertical an angle as possible. [B] Push straight back toward contacts in the Printhead Holder. **NOTE: Be careful not to bend the contact pins in the Holder or to damage the surface of the Cartridge Printhead. (See cutaway images A and X above.)** [C] Make sure Cartridge is seated in Holder.
3. Close Latch Lever to secure Cartridge. **DO NOT** force Latch Lever into place.
4. Repeat Steps 1-4 for remaining Cartridges.



Ink in Cartridge may be harmful if swallowed. Keep new and used Cartridges out of reach of children. Discard empty Cartridges immediately.

Setting up Feed

1. Release Separator Locking Lever [A] (located on operator's side of Feeder), then raise Separators [B] to "up and locked" position. Move Side Guides [C] to outermost open position. Place one piece of media in center of Feed Table.
2. **Adjust Separators.** Use two Center Separators for narrow media and all four Separators for wide media. Place media under the Separators and lower the Separators so they rest on media.
3. Rotate the Locking Lever up to lock the Separators in place.
4. Loosen knobs on Side Guides. Adjust Side Guides to within 1/32" (0.8 mm) of media. Tighten knobs.
5. Adjust Rear Guide [D] so media is raised about 1/2" (12 mm) and rests on curve of Rear Guide. When running 10" (254 mm) or longer or heavy media you may have to set Rear Guide so that it just touches back of media.
6. Feed a piece of media through Printer and adjust two Exit Guides [E] so that they ride on media. To prevent smearing, make sure that Exit Guides do not track over any printed information.

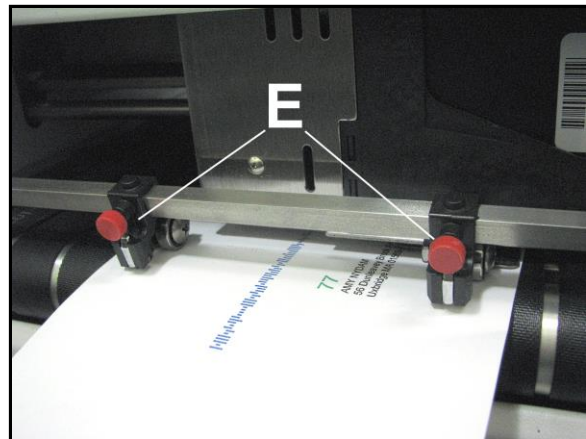
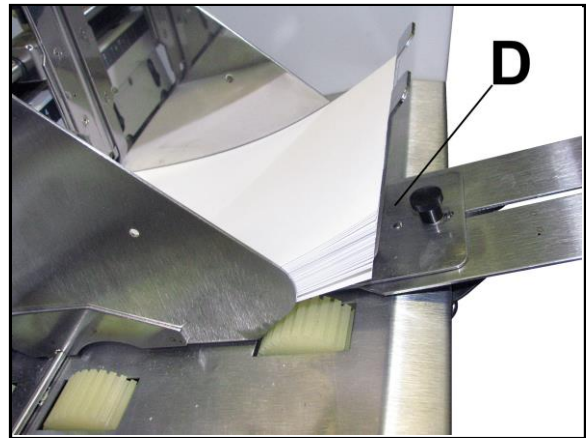
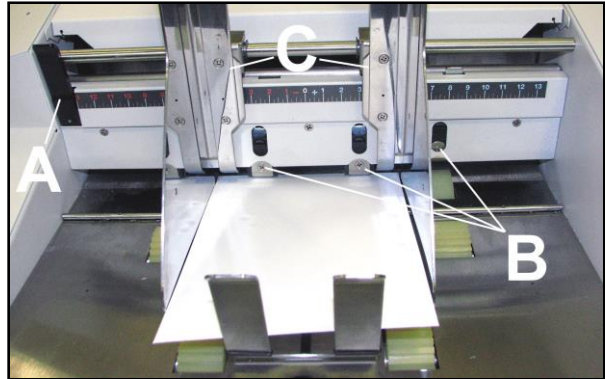

SECTION 2 INSTALLING PRINTER

7. **POSITIONING CARTRIDGE PRINTHEADS.** Adjust positioning of the Printhead Cartridge Assemblies by loosening the locking screws [F]. Slide the Assemblies as needed to print on media being used.

IMPORTANT! Raise the Printhead Cartridge Assemblies so they do not touch the conveyor belts before adjusting positioning.

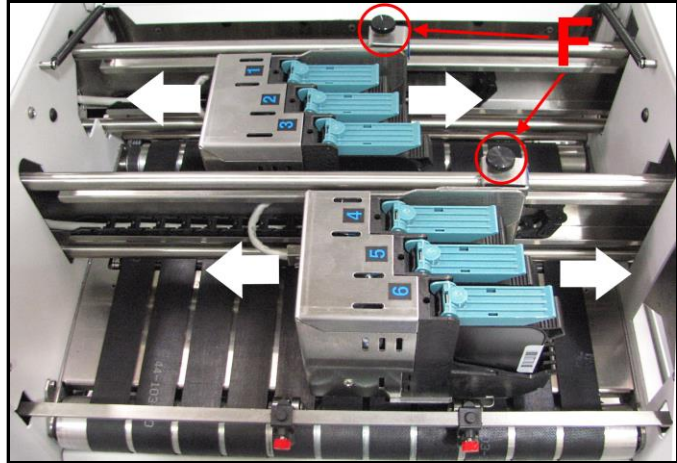

8. **Turn Printer ON.** Turn Media Thickness Knob [A] fully counterclockwise to raise the Printhead Carriage to its highest position.

Place a piece of media [B] under the Printhead Carriage. Adjust the Media Thickness Knob clockwise until the Printhead Carriage just touches the media.

Turn Media Thickness Knob counterclockwise until media [B] can be pulled from under Print Carriage with a slight pull.

NOTE: These are initial settings. It may be necessary to adjust the Media Thickness Control to optimize print quality. Make a note of the knob position for future reference for that media.

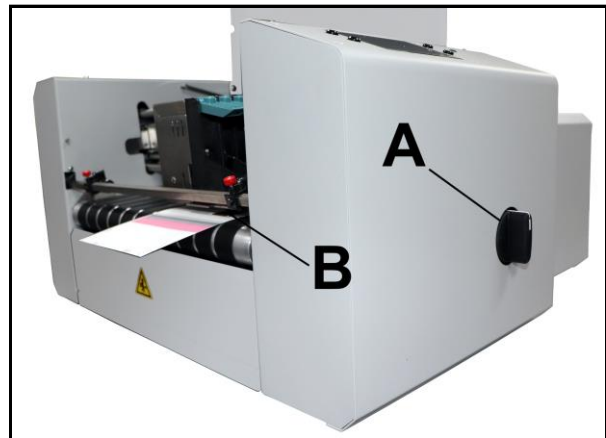

9. Test feed media by pressing “Test Feed” on the Quick Menu Touchscreen.

Install Printer Driver

Download the latest Printer Driver from the Printer manufacturer's website. **NOTE: You can also use the USB Flash Drive included with the Printer to install the Printer Driver.** Make sure the USB or Network cables are connected to the Printer and your computer and that the Printer is turned on.

- If your Network requires a static IP address, see “Network Settings”.
- If you wish to use WiFi, see “WiFi Setup”.

1. **Open the downloaded Printer Driver Folder (or open the USB Flash Drive Directory):**
Open the “Monochromes” folder.
Open the “Driver” folder.
Open the “Driver Version” folder.
Select and double-click “Setup.exe”.
2. “Add, Update or Delete Printer” window opens. Click “Add New Printer”. Click Next>.
3. The “Connect Printer” window opens. Make sure the Printer is plugged in and switched on and that it is connected by USB, Network or WiFi to your computer. Click “Yes”.
4. The “Want to Install Printer...” window opens. If that is correct, click “Yes”.

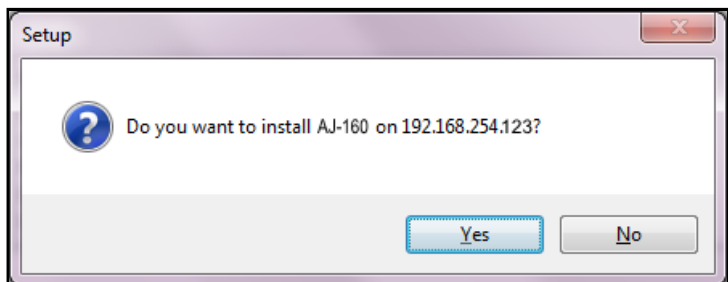
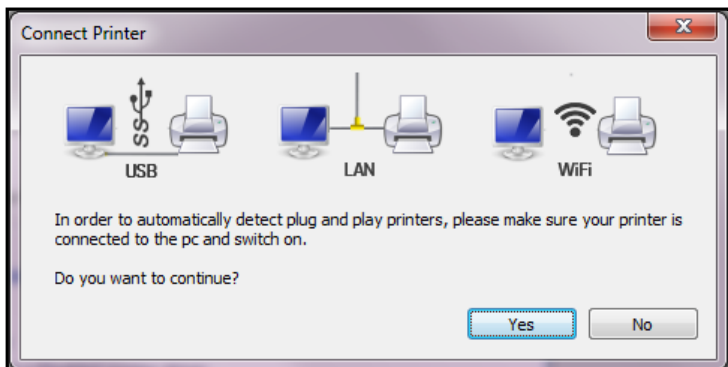
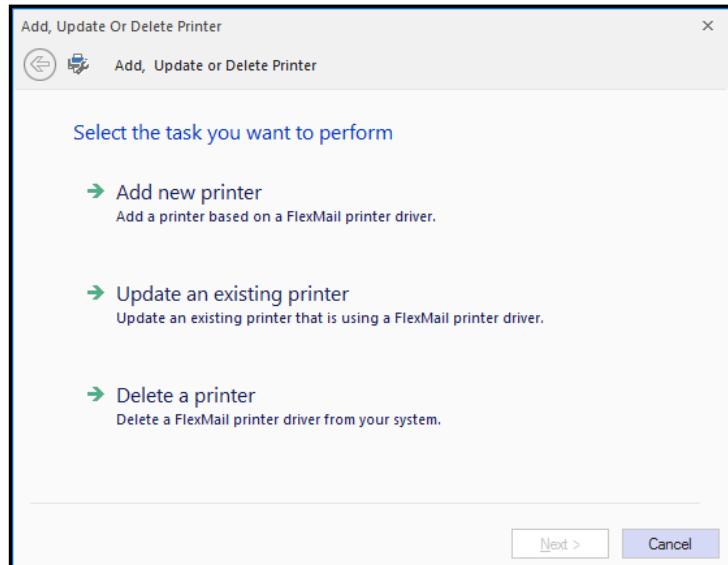

SECTION 2 INSTALLING PRINTER

5. The Driver will load and the next screen opens to allow you to “**Type a printer name**”. Unless another printer has the same name on your system or network, ignore this step and click **Next>**.
6. Click **Finish** to complete the installation.
7. In “**Devices and Printers**” check that Printer is available and active.
8. **Using the Printer Touchscreen:**
Press the **Network** icon on the **Tools** screen to open the **Network Settings** screen. Select **Network Setup** to enter the settings for connecting the Printer to your network. **Uncheck** the **DHCP** box. This will ensure that the Printer's IP address won't change each time the Printer is powered down.

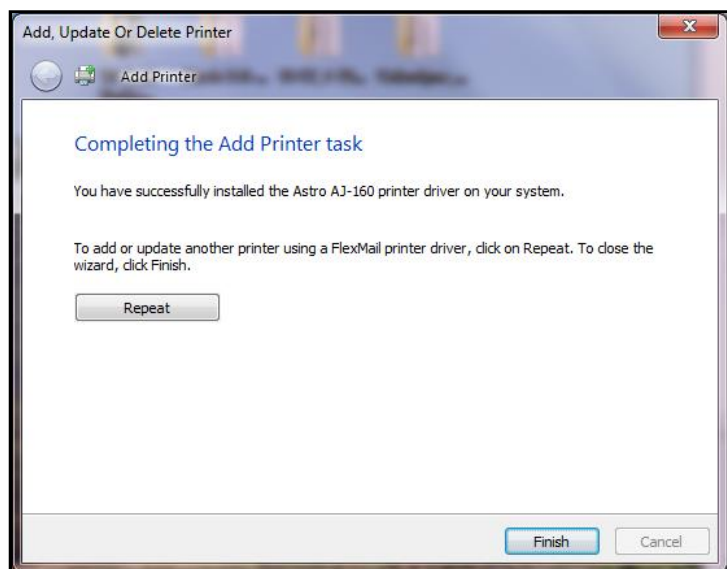
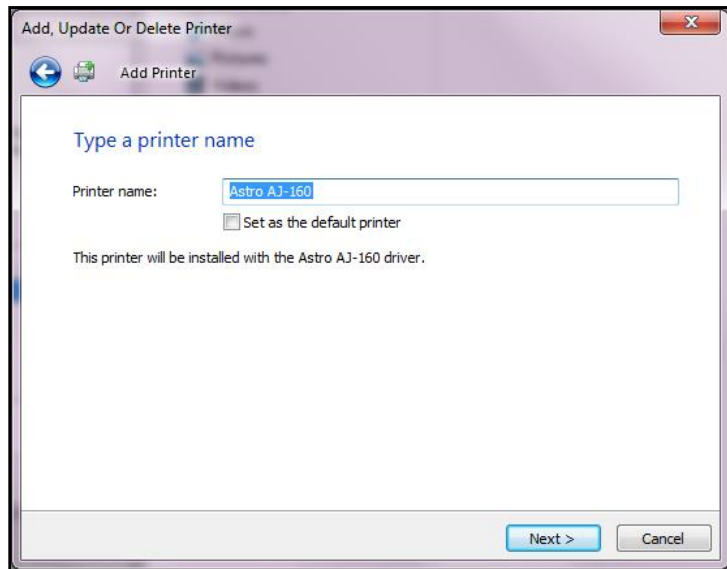
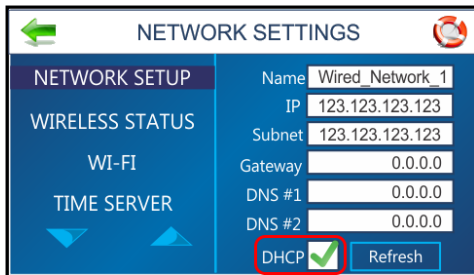

Install Printer Update Utility

To implement Printer Firmware updates, you will need to install the **Printer Update Utility** software included on the USB Flash Drive supplied with your Printer. Make sure the USB or Network cables are connected to the Printer and your computer and that the Printer is turned on.

1. **Open the USB Flash Drive:** Click the “**Monochromes**” folder. Click the “**Utility**” folder. Double-click “**Setup.exe**”.
2. The “**Printer Update Utility Setup**” window opens. Click “**Next**”.
3. The “**Select Installation Folder**” window opens. Select “**I agree...**”. Install the software in the “**Program Files**” folder (*default*) or enter a new location or click “**Browse**” for a different folder. **NOTE:** You can install the **Update Utility** to be used by anyone who logs into the computer, “**Everyone**,” or only for use when you are logged into this computer, “**Just Me**”. When ready, click “**Next**”.
4. The “**Confirm Installation**” window opens. Click “**Next**”.
5. A “**Do You Want to Allow...**” window opens. Click “**Yes**”.

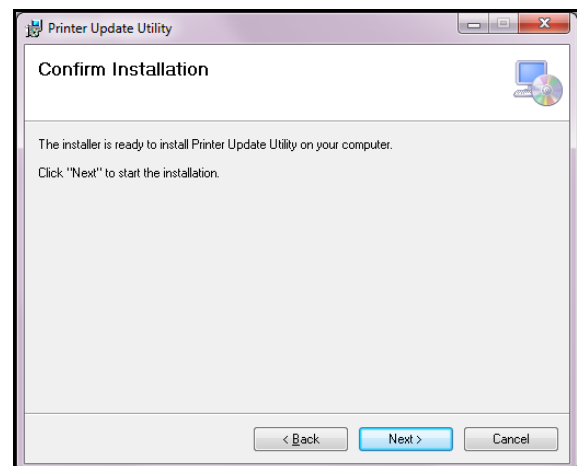
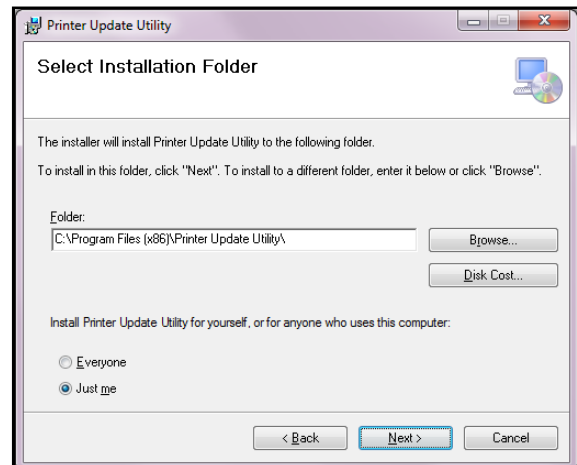
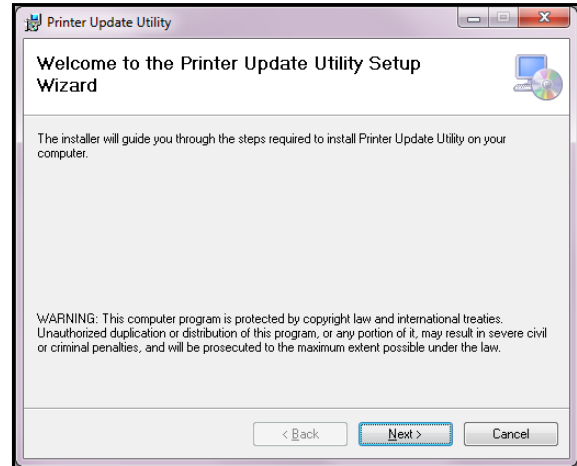

SECTION 2 INSTALLING PRINTER

6. The **Printer Update Utility** is installed.
7. The **“Installation Complete”** window opens.
Click **“Close”** to exit.

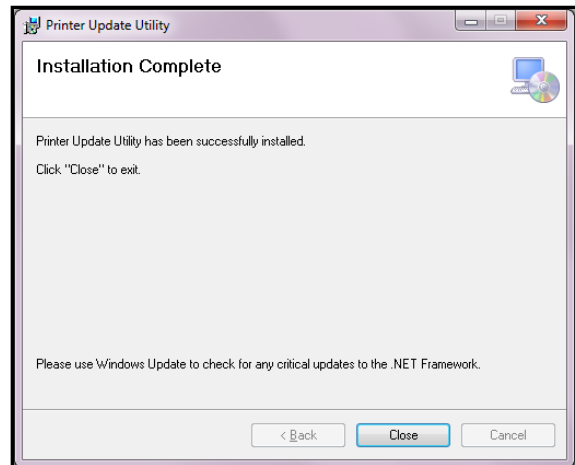
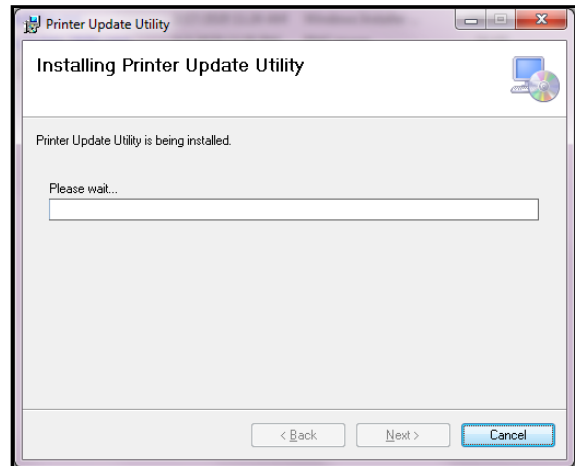

SECTION 3 – *Operating Printer*

Control Panel Touchscreen or through the **Printer Driver** loaded on your computer. The “**Operating Printer**” section is divided into two parts. The first describes the function of the **Printer Control Panel Touchscreen**. The second section describes **Driver Properties** and various options available when running a job.

Printer Driver installed in **Section 2** should be set as the default driver. It is then accessible through your applications (*such as Microsoft Word*). Other types of applications and database management software will work in a similar manner using the **AstroJet 160 Driver**. This Section further assumes that feed is set up and Printer is connected to your computer.

Using the Touchscreen

The **Control Panel Touchscreen** turns on when the Printer is turned on. Use the Touchscreen and/or Printer Control Panel keys to access various functions that help you control or customize Printer operation.

BASIC TOUCHSCREEN INFORMATION

Green Arrow: Tap or press to return to the previous screen.

Help Icon (Life Preserver): Tap or press the icon to open a short description of the features found on that screen.

Cleaning: See “**Cleaning the Touchscreen**” in the **Maintenance** section.

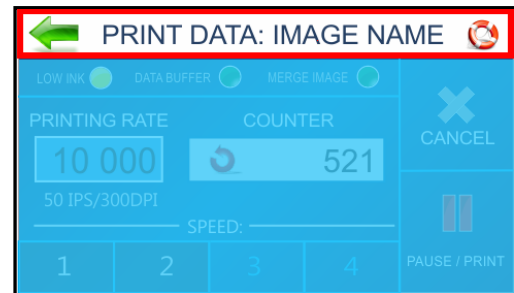

SECTION 3 OPERATING PRINTER

TOUCHSCREEN KEYBOARDS

Use the **Touchscreen Keyboards** when entering or editing information in entry boxes in features such as **Network Settings**. The appropriate keyboard opens when you tap on an **Edit Box** and/or tap within a data entry box on the Touchscreen.

- “**C**” to the left of the white entry box clears the box.
- “**Arrow**” to the right of the white entry box deletes last character entered.
- Press “**Enter Arrow**” on lower right of keyboard to save your entry.
- Press “**Up Arrow**” to toggle between upper and lower case letters.
- “**SP**” is the space bar.
- “**123**” opens the numeric keyboard.
- “**#+=**” on the numeric screen opens the symbols keyboard.

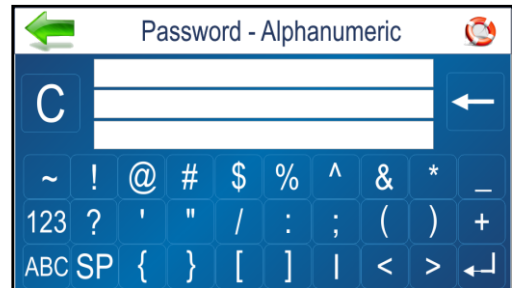
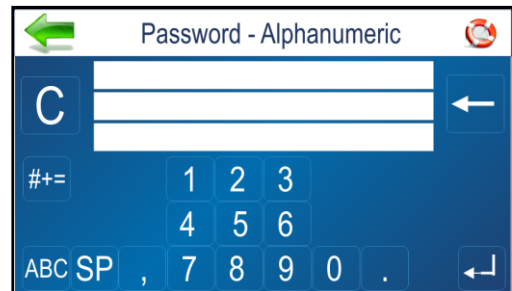
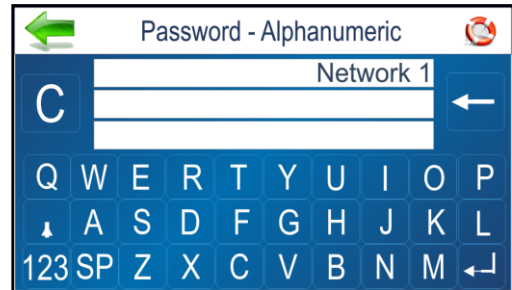

MAIN MENU

Tap or press the icons to access features built into the Printer and to customize Printer operation.

Print Image: Find and set up new or current jobs and/or images for printing.

Printer Set-up: Set Printer parameters to adjust the Printer to suit your needs.

Tools: Run **Ink Cost Estimator**, **Ink Status**, **Diagnostic tests**, **Network**, and **Screen Calibration**.

Print Data: Displays information about the job printing.

Test Print: Prints a test page using current adjustments and print parameters to check printing quality and Printhead alignment.

Info: Displays information about the Printer.

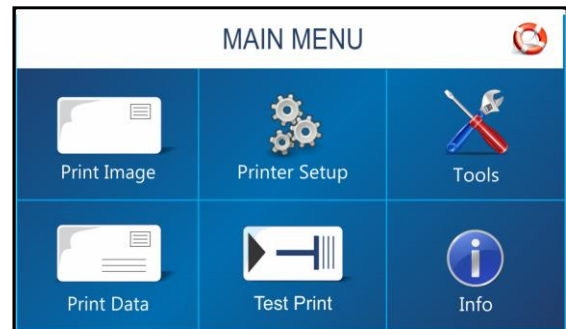

PRINT DATA

Shows information about the job currently printing.

Low Ink: Indicator appears when ink is running low.

Data Buffer: Indicator shows whether variable data is loaded. **Red**-No variable data loaded. **Green**-Variable data loaded. **Flashing**-Variable data loading.

Merge Image: Indicator shows whether or not an image is loaded. **Green**-Image loaded.

Merge Clear Button: Allows you to clear a merge and continue printing without having to cancel the job.

Printing Rate: Shows how many pieces are printing per hour. Also displays the **Speed (ips)** and **Print Quality (dpi)** set for the print job.

Counter: Shows the number of pieces run for a particular job.

Reset Button (inside Counter box): Resets **Counter** to 1.

Speed: Shows print speeds (1-4) available for a print job.

Cancel: Cancels a running or paused print job.

Pause/Print: Press to print a job, pause a running job, or to restart a paused job. **NOTE: You can also perform these functions using the Feeder ON/OFF button on the Control Panel.**

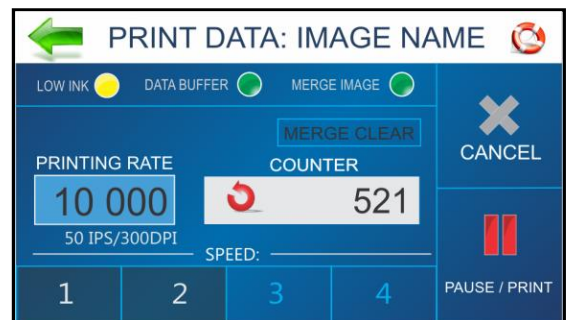

INFO

Displays information about the Printer.

Model Name: Printer model.

BIOS version: Current version of firmware installed.

Max. Printheads: Number of Printheads in this model Printer. (*x's or number = printhead installed. -'s = printhead missing or problem.*)

Firmware Notice: Displays firmware status. The **CLEAR** button removes the notice.

Clock: Displays current time.

Cartridges used: Total number of ink cartridges emptied by the Printer.

Pieces-Lifetime: Total number of prints that passed through the Printer. Non-resettable.

Jobs: Total number of jobs run on the Printer lifetime.

Session: Total number of jobs run on the Printer since last power-down.

Port(s) in Use: Displays which Printer ports are being used.

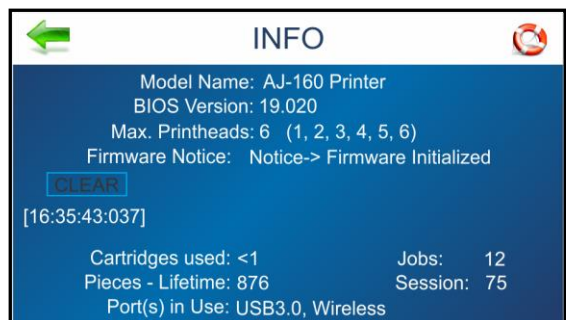

SECTION 3 OPERATING PRINTER

PRINT IMAGE

Pressing the **Print Image** icon on the **Main Menu** opens the **Print Image** screen. Used to find and set up new or current jobs and/or images for printing.

File Info: Displays current jobs/images in the **Image Library** including printing parameters. Use the arrows to scroll through and select images from the **Printer Image Library**. Press the white button to display up to four current images simultaneously.

Import: Puts the Printer in **Save** mode to save a new job or image sent from the database into the **Printer Image Library**.

Print: Opens the **Print Setup** screen (*see next page*).

Delete: Deletes the job or image from the Printer Image Library.



PRINT IMAGE – FULL SCREEN PREVIEW

Tap or press the image on the **Print Image**, **Print Data** or **Reprint** screens [A]. Image will fill the Touchscreen for easier viewing [B]. Tap image again to return to normal screen view.

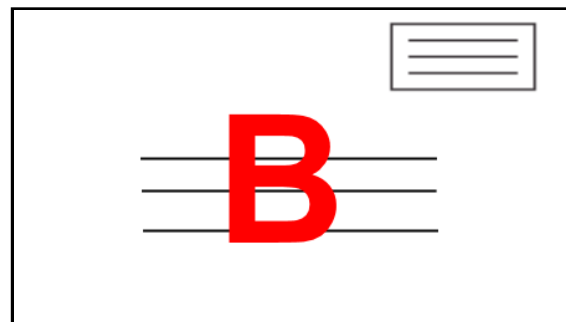

PRINT IMAGE – IMPORT

Printer is ready to save a new image sent from the database. Send the image from your computer to the Printer as a single-page job. Image will be saved with printing parameters (*Page Size, Print Quality*).



PRINT IMAGE – DELETE

Job or image is being permanently deleted from the **Print Image Library**.

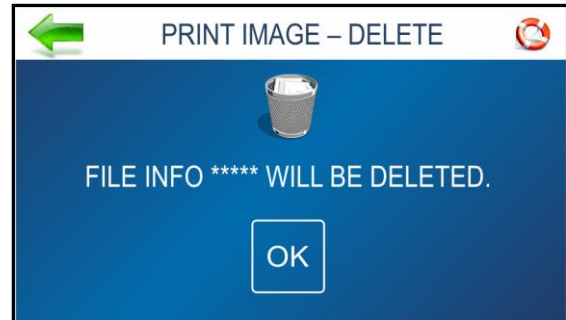

PRINT IMAGE – SET-UP

Pressing the **Print** icon on the **Print Image** screen opens the **Print Image Set-up** screen. Once a job is loaded, the image name and dpi it was sent at are displayed at the top of the screen.

Counter: Enter the number of copies to be printed. Printer counts down from the number set on the screen.

Reset button (*inside Counter box*) resets Counter to **1**.

Print Quality: Shows **Speed** in inches per second (*ips*) and **Print Quality** (*dpi*) set for the print job.

NOTE: Print Quality is determined by the **Print Resolution** set in the image or print job.

Speed: Shows the speeds available (**1=Slowest; 4=Fastest**) for a particular job. **NOTE:** Speeds available are determined by the **Print Resolution/Print Quality** set in the image or print job.



Merge: Merge Image with a database. New job must match Page Size and Layout of merged image.

NOTE: To Merge with a database, the image must be saved at 600 dpi.

Print: Press to start printing the job. Also opens the **Print Data** screen that allows you to monitor the status of the printing job.

Once the selected print job is loaded/printing, the Print Data screen opens:

Low Ink: Indicator appears when ink is running low.

Data Buffer: Indicator shows status of variable data to be loaded. **Red**-No variable data loaded. **Green**-Variable data loaded. **Flashing**-Variable data loading.

Merge Image: Indicator shows whether or not an image has loaded. **Green**-Image loaded.

Merge Clear Button: Allows you to clear a merge and continue printing without having to cancel the job.

Printing Rate: Shows number of pieces printing per hour.

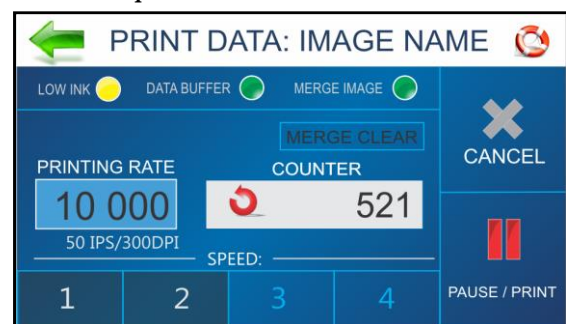

Counter: Shows the number of pieces run for a particular job.

Reset Button (*inside Counter box*): Resets **Counter** to **0**. The Counter can be set to reset between jobs manually or automatically, see **Continuous Batch Counter** in **Printer Preferences**.

Cancel: Cancels the print job.

Pause/Print: Press to print a job, pause a running job, or press to restart a paused job. **NOTE: You can also perform these functions using the Feeder ON/OFF button on the Control Panel.**

SECTION 3 OPERATING PRINTER

PRINTER SET-UP

Pressing **Printer Set-up** on the **Main Menu** opens the **Printer Set-up** screen. Features on this screen allow you to set Printer parameters to adjust the Printer to suit your needs.

Ink Type: Displays the Ink Types loaded in the Ink Cartridge Holders. Only authorized Ink Cartridges will display. Selecting an Ink Type allows editing options to be available.

Printer Preferences: Select from a list of Printer actions and/or set a **Feeder Stop** and **Conveyor Gap**.

Language: Select the language the Printer Touchscreen will display.

Horizontal Alignment: Fine-tune the spacing of the Printheads (1-6) in relation to each other horizontally (*side-to-side*).

Vertical Alignment: Fine-tune the spacing of the Printheads (2-6) in relation to each other vertically (*front-to-rear*).

Factory Default: Returns the Printer Setup to factory default settings.

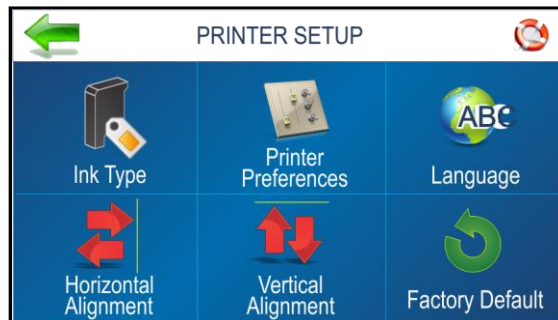

INK TYPE

Functions found on this screen:

Select Ink Type: Select the recognized Ink Cartridge installed in a particular Cartridge Holder [1-6]. Tap the entry to select the Ink Cartridge. Tap the **Edit** box to open the **Ink Specifications** screen.

NOTE: Only authorized Ink Cartridges will be recognized by the Printer. An empty cartridge holder or invalid or unprogrammed Ink Cartridge will display as “-----”. An Ink Cartridge that is programmed, but not recognized by this Printer displays as “???????”.

Ink Type Specifications (Paper/Pencil icon): Displays the Ink Type and Boost entry box. Tap the **Boost** entry box to increase voltage for that Ink Cartridge up to the maximum recommended (*see below*).

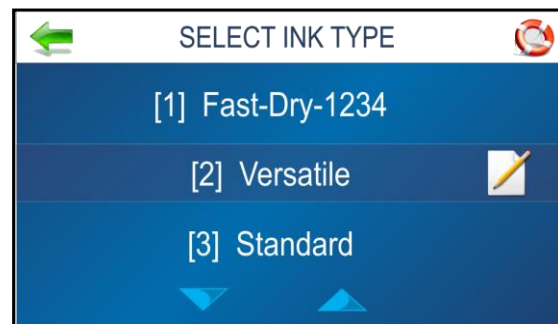

EDIT INK TYPE

Boost the voltage on a particular ink cartridge to improve print performance under certain conditions. Once entered, the Printer memory will recall this information even if the Cartridge is removed and reinstalled in this Printer later.

CAUTION

Boosting the voltage above the maximum shown will damage the Ink Cartridge, Cartridge Holder and Printer.

Press the **Boost** entry box to open the **Numeric Keyboard** to increase the voltage on a particular Ink Cartridge. **DO NOT increase the voltage more than the maximum listed on the touchscreen.**

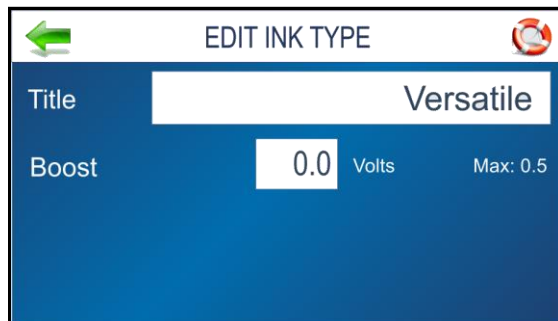

PRINTER PREFERENCES

This menu is also available by pressing **Quick Menu** key on the Control Panel. Note that **Tray Break** also has an **Edit** icon. Tap or press the icon to open the **Edit** screen. Press ">>>>" to go to next screen. Press "<<<<" to return to the previous screen.

Purge First Piece: Turning this feature ON causes the Printer to send one purge pattern on the first piece. After purge is completed, the next piece will be the first record of your database. Once this feature is selected, it remains ON, even if Printer is turned OFF.

Select = Purge. **Deselect** = No Purge or Stop Purge.

Automatic Feed Start: Turning the feature ON causes Printer to start feeding once the job is sent. Printer will come **Online**, the Printer starts feeding and printing automatically. Turn this feature off to use the **Print** button on Touchscreen (or **Feeder ON/OFF** on Control Panel) to start printing. Turning the Printer ON or OFF does not affect your selection. **Select** = Auto Feed Start. **Deselect** = No Auto Feed Start.

Keep Nozzles Alive: Prevents unused Printhead nozzles from becoming dehydrated during a printing job.

Select = Nozzles spit to stay hydrated. **Deselect** = Nozzles do not spit. **Edit box:** Set the spitting frequency: **1x**, **2x**, **4x** (default), and **8x**.

1x
2x
4x
8x
600 dpi Test

The **600 dpi Test** spits through all the nozzles at once. (*Example: This might be used to find a problem with the Printhead nozzles or to clear the printhead after sitting idle for long periods of time.*)

Tray Break: Printer will search for break marks (spaces between media pieces) and respond according to settings. **Select** to pause or set a gap within a print job. **Edit box** = Select and set the **Feeder Stop** and timing or select the **Conveyor Gap** and set gap/break spacing. (*See below*)

Continuous Batch Counter: **Unchecked** = Batch Counter resets before each job. **Checked** = Batch Counter will not reset before each job.

Feeder Delay: Used to lengthen the time between pieces being fed. (*Example: Jobs that require longer drying time before they are stacked.*) **Unchecked** = No Feeder Delay. **Checked** = Feeder Delay activated. **Edit Box:** Set the amount time the Feeder will pause in tenths of a second. (*See below*)

NOTE: This applies only to internal print jobs on the Printer (*Example: Test Print, Purge Print* and images stored in the **Printer Image Library**). Any print jobs sent to the Printer with this parameter already set in the job setup will override this feature. **Unchecked** = No Feeder Delay. **Checked** = Feeder Delay activated. **Edit Box:** Set the amount time the Feeder will pause in tenths of a second. (*See below*)

Printer Sleep: **Checked** = Printer will go into **Sleep Mode** after being idle for a preset period of time. **Unchecked** = Printer never goes into **Sleep Mode**.



SECTION 3 OPERATING PRINTER

TRAY BREAK SETTINGS

Feeder Stop: Select and set the timer to pause/stop the Feeder at predesignated breaks during a print run. Enter time in seconds (1-60). On sensing the break mark, the feeder stops for x number of seconds.

Conveyor Gap: Used when Printer is set up in line with other mailing equipment (*conveyors, tabbers, etc.*) When this feature is activated, Printer responds to the “break mark” by sending a signal to the conveyor to speed up momentarily. This creates an obvious gap between end of one set of pieces and beginning of the next. Select and set the gap on a conveyor between predesignated breaks during a print run. Enter the distance between the Media Sensor and the Conveyor. The Printer sends a delayed signal to an external device and continues to feed.

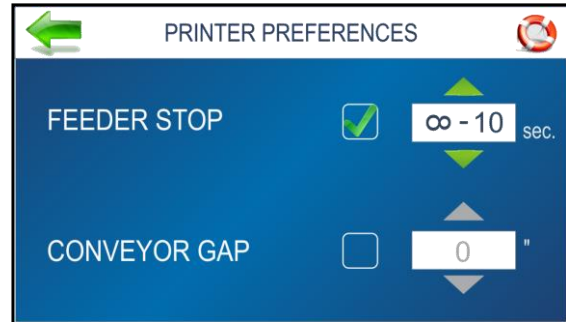

FEEDER DELAY

Feeder Delay: Select to lengthen the time between pieces being fed. (*Example: Jobs that require longer drying time before being stacked.*) **NOTE:** This applies only to internal print jobs on the Printer (**Example: Test Print, Purge Print** and images stored in the **Printer Image Library.**) Jobs sent to the Printer with this parameter already set will override this feature. **Unchecked** = No Feeder Delay. **Checked** = Feeder Delay activated. **Edit Box:** Set the amount time the Feeder will pause in tenths of a second.

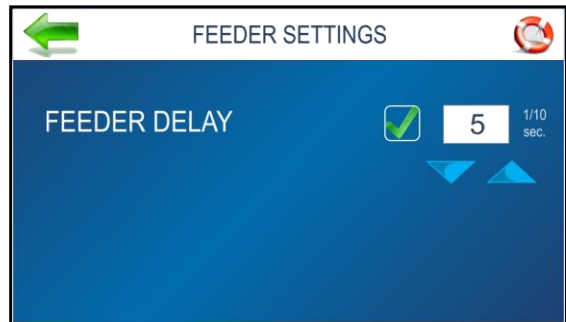

SELECT LANGUAGE

Select the language that the Printer Touchscreen will display.



FACTORY DEFAULT

Restores **all** operator initiated adjustments and settings to factory settings.



HORIZONTAL ALIGNMENT

Adjusts offset of individual Printheads (*side-to-side*) offset to fine tune horizontal positioning of the printout.

Horizontal Alignment is also accessible by pressing the **Quick Menu** key on the Control Panel.

Heads (1-6): Align individual Printheads (*side-to-side*) up to ± 100.0 microns in 5.0 micron increments.

To use: Select the desired Printhead. Move the bar in the desired direction by pressing the directional arrows.

Reset: Horizontal alignment resets to **00.0** (*default*).

Test Print: Prints a test page using current adjustments and print parameters to check printing quality and Printhead alignment.

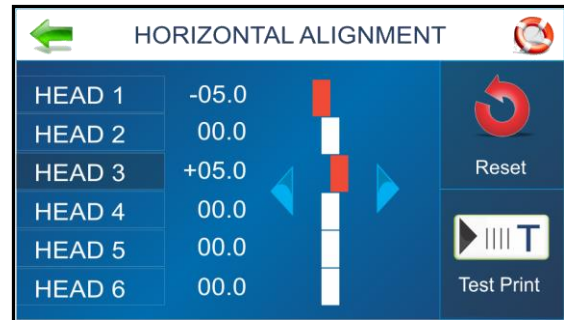

VERTICAL ALIGNMENT

Disables the top nozzles in individual Printheads to remove any overlap to fine tune vertical positioning of the printout.

Vertical Alignment is also accessible by pressing the **Quick Menu** key on the Control Panel.

Heads (2-6): Adjust individual Printheads up to ± 1.0 microns in 0.1 micron increments.

To use: Select the desired Printhead. Move the bar in the desired direction by pressing the directional arrows.

Reset: Vertical alignment resets to **0.0** (*default*).

Test Print: Prints a test page using current adjustments and print parameters to check printing quality and Printhead alignment.



PRINTER TOOLS

Press **Tools** icon on **Main Menu** to open the **Tools** screen.

Estimator: Select to set up an **Ink Cost Estimate** for a particular print job. The Printer runs, but does not print a preset sample number of pages (*up to 50 pages*) of the job to be printed. (*Set the number of pages in the Print Driver.*) The **Estimator** then determines the estimated ink cost for the entire print job.

Ink Status: Select to view the percentage of ink left in the ink cartridges and the estimated number of prints remaining for each cartridge at a selected resolution, based on the last page printed.

Diagnostic: Select to run diagnostic tests on key Printer systems and components.

Network: Set up access to a network. Also set up **Wi-Fi** capability for wireless access to a network. **Wireless Status** displays network information about the Wi-Fi connection. The **Time Server** displays information about the source used for date and time when the Printer is connected to an Internet-connected network.

Screen Calibration: Set the touch pressure (*touch sensitivity*) desired to activate the Touchscreen.

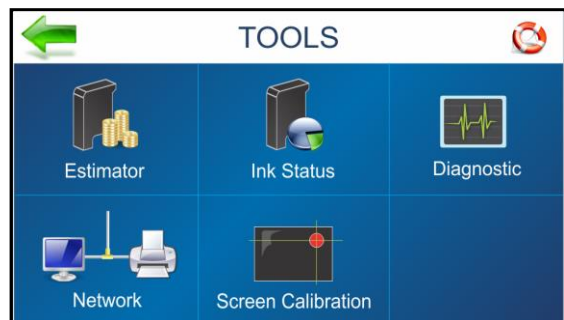

SECTION 3 OPERATING PRINTER

INK ESTIMATOR

This tool estimates the cost of ink for a particular print job. The Printer runs and simulates printing a preset number of pages. Set the job to print 1-49 pages (*in the Print Driver*) for the printer to make the estimate. Generally, the higher the number of pages sent, the more accurate the estimate.

NOTE: It is recommended that **Purge First Piece** be turned off. This will use much less ink and increase the accuracy of the estimate.

Ink Cartridge Cost: Tap/press the entry box to enter the cost of the ink cartridges.

Number of Pages: Tap the entry box to enter the total number of pages for a given job.

Start Estimation Mode: Tap or press to start the Ink Estimator.

Estimated Ink Cost: Displays the estimated ink cost for the entire print job.

Ink Estimation - Cartridge Cost

C 30.0

1 2 3 4 5 .

6 7 8 9 0

INK ESTIMATOR

Ink Cartridge Cost 40.00

Number of Pages 10 000

Estimated Ink Cost

Processing Page No Purge First Piece

CANCEL

START ESTIMATION MODE

INK ESTIMATOR

Ink Cartridge Cost 40.00

Number of Pages 10 000

Estimated Ink Cost

Processing Page No Purge First Piece

CANCEL

PRINT UP TO 50 PAGES NOW

INK ESTIMATOR

Ink Cartridge Cost 40.00

Number of Pages 10 000

Estimated Ink Cost 25.20

Processing Page 50

CANCEL

START ESTIMATION MODE

INK STATUS

Shows the percentage of ink remaining in each Ink Cartridge and the estimated number of prints remaining at a selected resolution. (*Resolution is selectable.*)

NOTE: Estimation is based on the last page printed.

“-----” Indicates no Ink Cartridge present or an unrecognized, unprogrammed Ink Cartridge.

“????????” Indicates an Ink Cartridge not programmed for this Printer.

Ink Status is also accessible by pressing the **Quick Menu** key on the Control Panel.

INK STATUS

HEAD#	%	LIFE	
[1]	100	10 000	150
[2]	-----		200
[3]	100	10 000	300
[4]	????????????		600
[5]	100	10 000	
[6]	100	10 000	

DIAGNOSTICS

Runs tests on Printer components and systems listed on the screen at variable speed.

To run Test: Remove media from the Printer. Press **Start Test** to start the diagnostic cycle. Press again to stop. While **Test** is activated, run one piece of media through the Printer to test the Sensor function. The **Test** cycles through each component automatically. Green lights indicate component is functioning properly.

NOTE: After running one piece, verify that the piece length was measured accurately. If the piece fed through, but no piece length was displayed and the Sensor condition still shows red; stop this test, power off the Printer and clean the Media Sensor.

If the piece measured longer than the actual piece length; the piece is probably slipping or hesitating as it feeds. In this case, check or adjust the Sheet Separators and check and adjust the Media Thickness setting.

Clutch w/Sensor: Unchecked box: Tests clutch function (on/off) using an automated routine.

Checked box: With media loaded, tests Clutch and Media Sensor function.

Conveyor: Checking/unchecking the box turns the conveyor relay on and off. (*Listen for relay clicking.*)

Feeder: Checking/unchecking the box turns the feeder relay on and off. (*Listen for relay clicking.*)

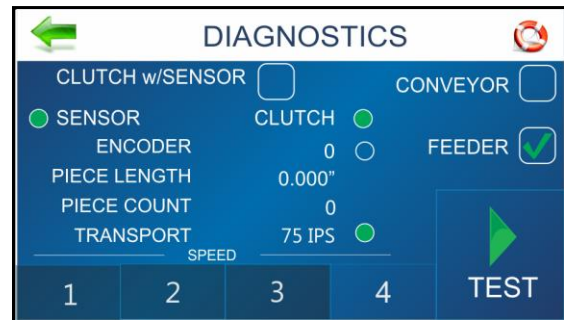

NETWORK SET-UP

Press the **Network** icon on the **Tools** screen to open the **Network Settings** screen. Select **Network Setup** to enter the settings for connecting the Printer to your network. Enter the Printer Name, IP address, Subnet address, Gateway address, DNS #1 and DNS #2 and select or deselect DHCP as needed. **Refresh** refreshes/updates the network connection.

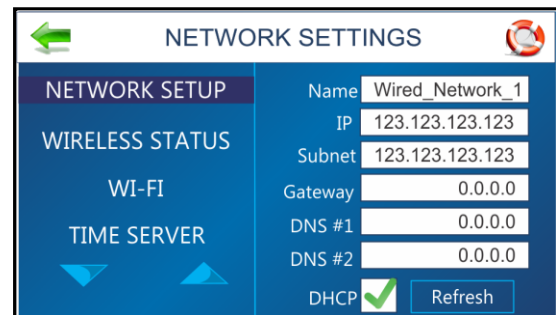

WIRELESS STATUS

Once the **Network** and **Wi-Fi** are set up, this screen displays information about the wireless network connection.

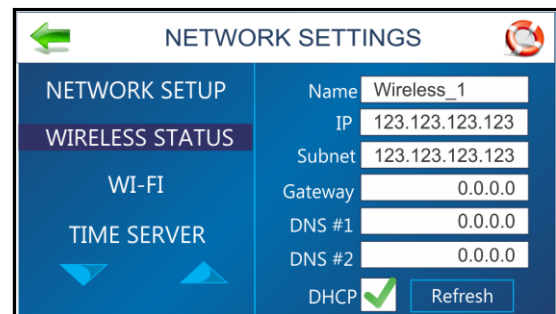

SECTION 3 OPERATING PRINTER

WI-FI SET-UP

Press the **Network** icon on the **Tools** screen to open the **Network Settings** screen. Make sure the Wi-Fi antenna (*included*) is connected to the Printer's Wi-Fi port.

1. Select **WI-FI**.
2. Select the desired Network from the list of **Wi-Fi Networks**.
3. Enter **User ID** and **Password**. Click **OK**.
4. Screen will show if you are connected to the Network. If connection fails, try again. Check that you are connecting to the correct Network. Check User ID and Password.
5. Click **Disconnect** to end connection.

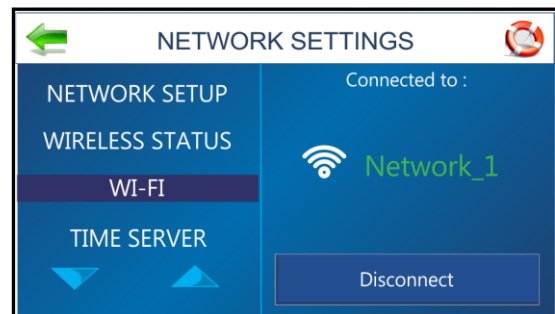
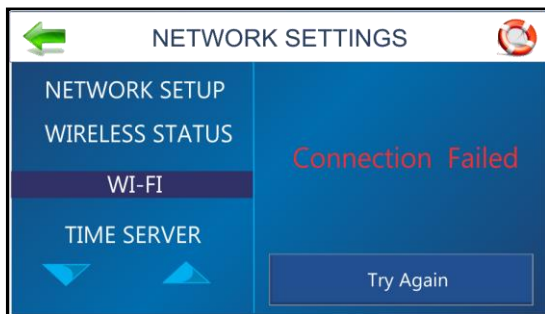
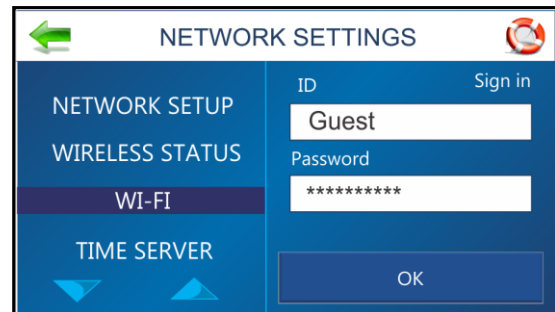
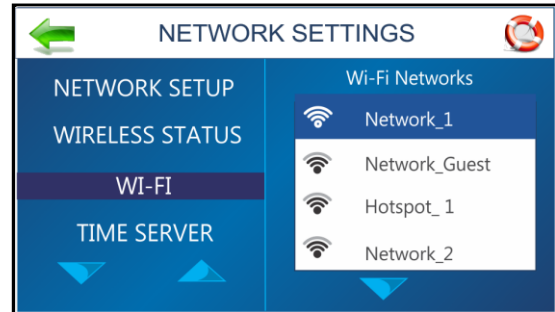

TIME SERVER (DATE AND TIME)

Displays the IP address of the Time Server being used and/or the Time Server's network name.

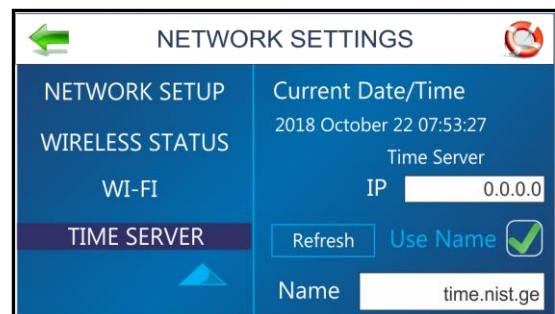

TOUCHSCREEN CALIBRATION

Adjust the touch pressure (*sensitivity*) needed to activate functions on the Touchscreen. (*Lower percentage = less pressure, more sensitive. Higher percentage = more pressure, less sensitive.*) Follow instructions on the screen to perform the calibration. **Time Remaining** counts down the 15 seconds given to complete each step. A screen message informs you if the calibration succeeded or failed.

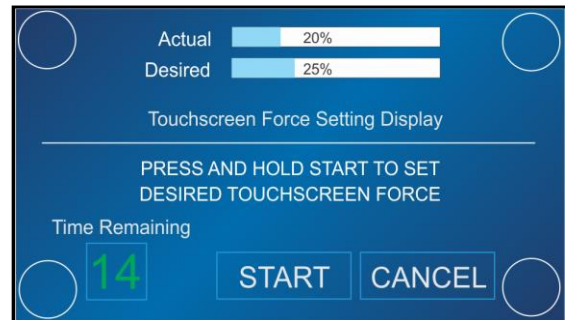

Power Button

When the **Power ON/OFF** button on the Control Panel is pressed, the **Power** screen opens.

Functions found on this screen:

Restart: Stops and restarts the Printer's software and electronics.

Shutdown: Safely shuts down software and powers off Printer. Once Printer shuts off you can safely turn the Main Power Switch OFF.

USB Disconnect: Disconnects or reconnects Printer communication with the USB Port

Sleep Now: Puts the Printer in Sleep Mode. Wakes when the Display Screen is touched or a job is sent to the Printer through the USB or network.

Port Reset: Clears any jobs being sent to the Printer. **Example:** After a job is cancelled at the Printer, the remainder of the job may continue to be sent by the computer. This may cause the Printer to get "stuck" because it can no longer read the job. Press the **Port Reset** button to fully clear the job. **NOTE:** Usually once the **Power ON/OFF** button on the Control Panel is pressed, this action happens automatically and the **Port Reset** button will be inactive. If the **Port Reset** button is still active, you can press it to clear the job.

Cartridge Initialize: Resets/reestablishes communication between the printhead cartridges and the Printer.

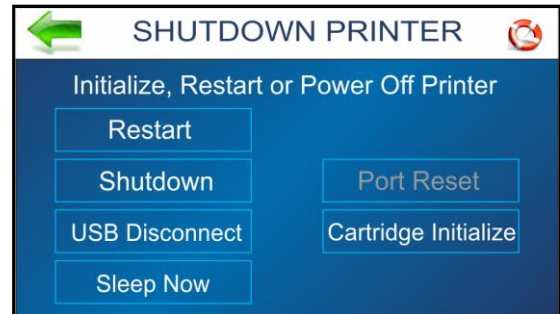

Firmware Updates

To install a firmware update:

Once a firmware update is sent to the Printer, the "**Firmware Updates**" screen appears on the Printer's Touchscreen. It will also appear when the **Power** button on the Control Panel is pressed. The screen indicates how many update files are available. **NOTE:** If no firmware updates were sent to the Printer, the normal **Shutdown Printer** screen appears.

- Press "**Install Updates**" to load the new firmware.
- Press "**Postpone**" to install the firmware at a later time. **NOTE:** The **Firmware Updates** screen will appear each time the Control Panel **Power** button is pressed until the firmware update is installed.
- **Verify update installed:** Check the **Info** screen to verify that the firmware version matches the updated firmware version.



SECTION 3 OPERATING PRINTER

Quick Menu

Allows quick access to often-used Printer functions without having to scroll through a number of screens. Open by pressing the **Quick Menu** key on the Control Panel. Press **Quick Menu** key again to exit the screen. (See individual explanations of screens in “Using the Touchscreen” section.)

Test Feed/Reprint: Default is **Test Feed**. If no data is present, this button allows you to test feed blank sheets of media. In case of a Printer jam or double feed, the **Test Feed** button becomes **Reprint**. Recover missed or misprinted pieces by pressing **Reprint**. Use the arrows to go back to the initial misprinted piece (or further back if desired) to start reprinting. Press **Print** to start printing.

Purge Print: Prints an ink pattern at 600 dpi to clear all of the ink nozzles in all of the ink cartridges.

Horizontal Alignment - Heads (1-6): Adjust offset of individual Printheads (side-to-side) up to ± 100.0 microns in 5.0 micron increments.

Vertical Alignment - Heads (2-6): Disables top nozzles in individual Printheads to reduce nozzle overlap. Adjust up to ± 1.0 microns in 0.1 micron increments.

Printer Preferences: Select and set various Printer features including **Purge First Piece**, **Automatic Feed Start**, **Keep Nozzle Alive**, **Tray Break**, **Continuous Batch Counter**, **Feeder Delay** and **Printer Sleep**.

Ink Status: Shows the percentage of ink remaining in each Ink Cartridge and the estimated number of prints remaining at a selected resolution.

Resolution is selectable.

HEAD#	%	LIFE	
[1]	AMC-Standard	100	10 000
[2]	-----		200
[3]	AMC-2580	100	10 000
[4]	????????????		300
[5]	AMC-Versatile	100	10 000
[6]	AMC-Standard	100	10 000
			600

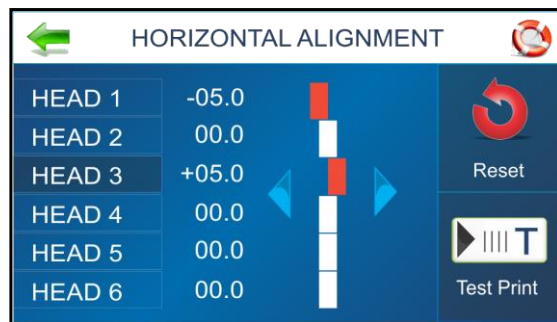
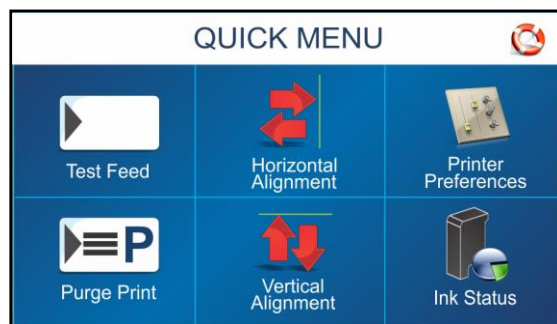

Printer Driver Properties

Printer Driver describes to the Printer how to print your job. It controls Printer operation and allows you to send fixed and variable text and graphics to the Printer. Within your data management software is a “**Print**” function. In that “**Print**” function is a **Properties** button. Through **Properties** you can control the Printer’s output. Use the **Properties Windows** to customize the Printer’s output.

To start printing, click **File**, then **Print**. “**Print**” window opens. To print the job, click **Print**.

To use the special features built into Printer Drivers; click “**Printer Properties**” to open the **Document Properties Window**.

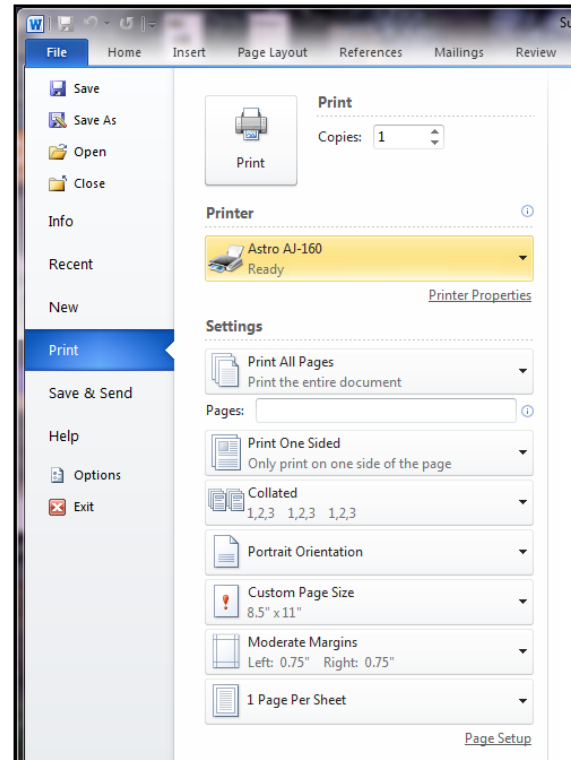

The **Layout** screen opens. The **Layout Tab** lets you select **Portrait** or **Landscape** orientation.

Clicking the “**Advanced**” button opens the “**Advanced Options**” screen.

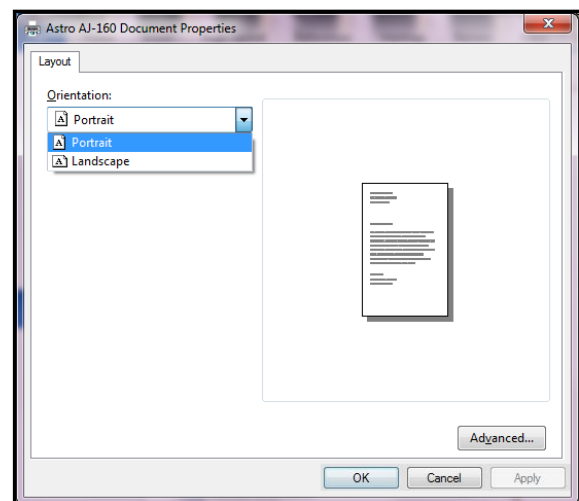

Document Options

Document Options is used to enable **Print Optimizations**.

Printer Features: Set Inverted Printing (*Yes/No*), set the resolution of Printer, set Printer speed, and add a delay to the feed to provide separation between pieces.

Print Inverted: In normal operation, printing is read from the operator side of the Printer. It is sometimes necessary to turn the printing direction 180 degrees from the normal direction. This occurs when, due to layout or method of binding, media must be fed in reverse direction.

Selecting and clicking on “**Yes**” permits you to reverse the printing direction 180 degrees. (“*No*” is the default setting.)

NOTE: Paper size is always “**Max Print Area**” and **Orientation** is always “**Portrait**”. **Do not change them.**

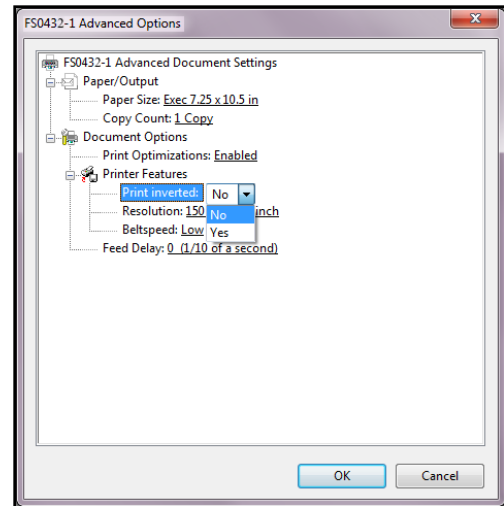

Resolution: Sets **resolution** of print quality. Changing **resolution** to a higher number (*e.g. 200 DPI to 600 DPI*) increases image quality. **NOTE: Higher resolutions reduce print speed options.**

AstroJet 160	
Resolution	Speeds Available
600 x 150 DPI	Low, Medium, Medium High, High
600 x 200 DPI	Low, Medium and Medium High
600 x 300 DPI	Low and Medium
600 x 600 DPI	Low

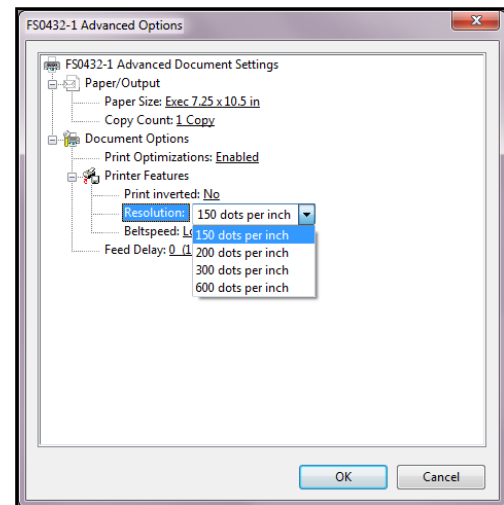

Belt Speed: Sets initial **Print Speed** for a print job. The speeds available for a particular job are determined by the **Resolution** set for the job.

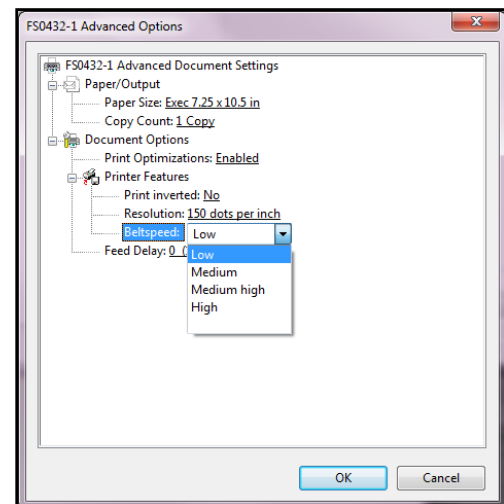

SECTION 3 OPERATING PRINTER

Feed Delay: Can be used to put more space between pieces as they are printed. This gives first piece printed more time to dry before next piece is printed.

Adjustment is made in 0.1-second increments.

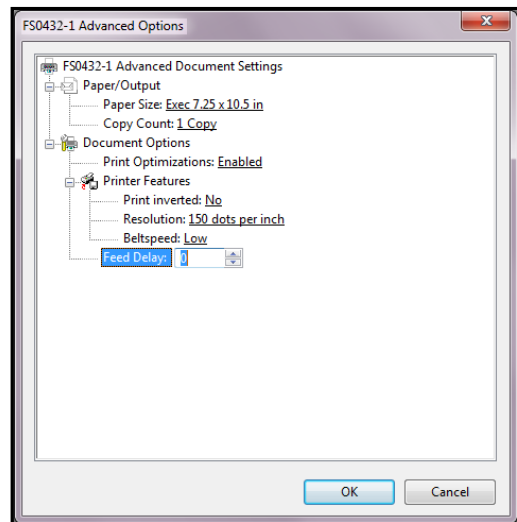

SECTION 4 - *Maintenance*

This section covers how to care for Ink Cartridges, clear paper jams, replace Sheet Separators, and perform routine maintenance on Printer.

Inkjet Cartridge

Inkjet Cartridges must be replaced when out of ink, when print quality is poor, or when purging and cleaning have not helped the image quality. Approximate life of Inkjet cartridges, based on three lines of 20 characters at 10-point size per address, is:

600 x 600 DPI	50,000 addresses
300 x 600 DPI	100,000 addresses
200 x 600 DPI	150,000 addresses
150 x 600 DPI	200,000 addresses

NOTE: These figures can vary depending on font selected.

IMPORTANT! AJ-140/AJ-160/AJ-180 Printers only work with authorized ink cartridges listed on the "Supplies and Optional Hardware" page. Other inks may become available; check with your local Astro dealer. **NOTE:** Not compatible with refills or other brands.

CAUTION

For continued protection against possible fire, use only genuine HP45 type Ink Cartridges, max. volume 50 ml.

MISE EN GUARD

Pour une protection continue contre les risques d'incendie, utilisez uniquement des cartouches d'encre authentiques de type HP45, volume max. 50 ml.

CAUTION

Never shake, drop or hit the Cartridge against the palm of your hand or any other hard surface. Shaking the Print Cartridge does not "mix" ink and hitting the Cartridge against a hard surface does not clear Nozzles.

These actions hurt print quality because they allow bubbles to form near the ink firing chambers. These bubbles prevent the nozzles from firing, causing white streaks in the print image.

SECTION 4 MAINTENANCE

Replace Inkjet Cartridge:

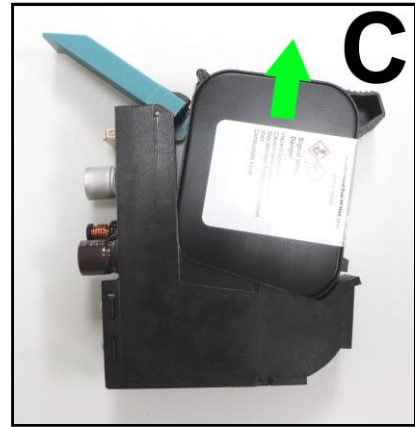
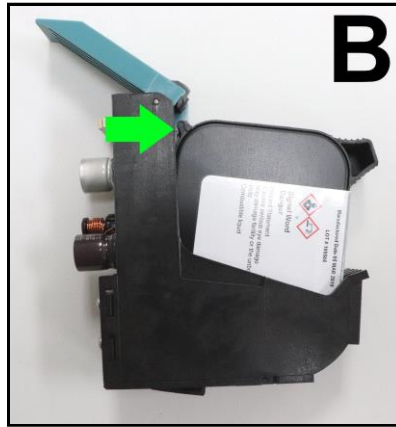
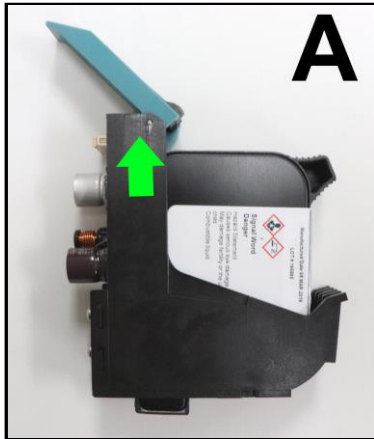

1. Open Latch Lever.
2. [A] Lift the Cartridge straight up until it stops (about 1/4").
[B] Pivot the Cartridge just enough so the tab on the Cartridge clears, but still touches the edge of the Latch Lever.
[C] Lift the Cartridge straight up and out of the Holder.
NOTE: Be careful not to bend the contact pins in the Holder or damage the surface of the Cartridge Printhead.



Install New Inkjet Cartridge:

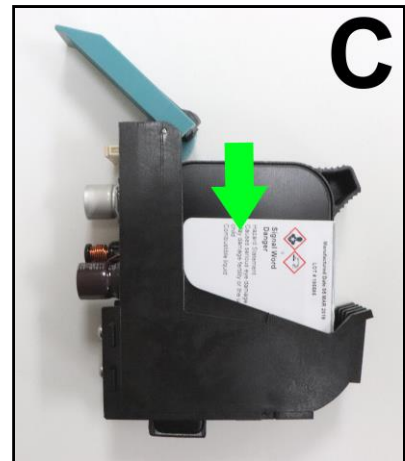

1. Remove new Inkjet Cartridge from packaging. Take care not to touch copper contacts, metal plate, or gold printhead. Remove protective tape from the Printhead.
2. [A] With Cartridge's Printhead pointing down and while keeping the Cartridge lightly in contact with the edge of the Latch Lever: Slide the Cartridge into Holder at as vertical an angle as possible.
[B] Push straight back toward contacts in the Printhead Holder.
NOTE: Be careful not to bend the contact pins in the Holder or to damage the surface of the Cartridge Printhead. (See cutaway images A and X above)
[C] Make sure Cartridge is seated in Holder.
3. Close Latch Lever to secure Cartridge. **DO NOT** force Latch Lever into place.
4. Repeat **Steps 1-4** for remaining Cartridges.

Storage

Short-term Storage (*less than 2 days or less than 1 day in a hot and dry environment*)

Leave Cartridge in Printer for short periods of time, 1 day or less.
Next time Printer is used, Printhead may have to be cleaned and purged.

Long-term Storage (*more than 2 days or more than 1 day in a hot and dry environment*)

Place Cartridges in a sealable plastic container with a damp sponge or towel to maintain humidity and prevent Printhead from drying out.

When Cartridges are ready to be used again, Printhead will need to be cleaned.

Disposal

Cartridges may be disposed of in a normal manner.

In case of an ink spill, use soap and water to clean up any problem areas.
Abrasive soap usually removes ink off of hands.

	<p>Ink in cartridge may be harmful if swallowed. Keep new and used cartridges out of reach of children. Discard empty cartridges immediately.</p>
---	--

Cleaning Printhead

Maintain good print quality by keeping Printheads clean. During printing process ink spray, paper fibers, and dust can build up on Printheads. This build-up eventually degrades print quality. If you notice problems with print quality, or to just prevent a build-up from occurring, wipe Printhead with a wet fiberless cloth.

<i>Cloth should be:</i>	<i>Cloth should not be:</i>
<ul style="list-style-type: none"> ✓ Soft ✓ Fiberless ✓ Moistened with water (<i>Distilled is best but tap water will work</i>) 	<ul style="list-style-type: none"> ✗ Abrasive ✗ Made of small fibers ✗ Dry or contain chemical additives

Wipe slowly across the long-axis with Printhead facing down (*as shown*). **DO NOT** apply excessive force, as this could scratch Nozzle area.



Purging Nozzles

If the Printhead sits inactive for a time, ink may dry in the nozzles. Printing may not remove these “ink plugs” from the nozzles. White streaks will show up in the printed text or graphic. In order to obtain better print quality, these ink plugs need to be forced out or purged. A **Purge Print** routine is built into Printer. Access this feature by using the **Quick Menu** key on the Control Panel.

1. Wipe Printhead with a wet cloth as described in “*Cleaning Printhead*” on previous page.
2. With media loaded in the Feeder, press the **Quick Menu** key, then “**Purge Print**” icon. Press “**Print**” to activate the purge. Purge prints an ink pattern at 600 dpi to clear all of the nozzles in all of the ink cartridges. **Repeat if necessary.**
3. Wipe Printhead again with a moist cloth.

NOTE: For more information, see Troubleshooting Printheads in Section 5 – Troubleshooting.

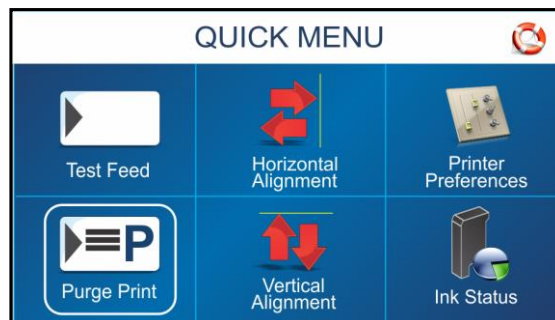

Jams in Printer

If a jam occurs, **STOP the Printer**. Recover missed addresses using the **Quick Menu** key on the Control Panel, then pressing “**Reprint**”.

Some possible reasons for jamming are:

1. Feeding more than one piece of media.
2. Damaged media, such as dog-eared (*turned down corners*).
3. Media that is not stiff enough may not be usable. Media that meets Postal stiffness requirements for automated feeding is acceptable in the Printer.
4. Envelopes caught under the flap of another envelope or stuck to one another may cause jamming.

Removing Jammed Media

1. It may be necessary to move one or more Printheads to gain access to jammed media. Take care when removing jammed media to avoid damaging Printheads. All pieces of jammed media must be removed from the feed path.
2. Follow instructions, *Section 3 – Operating Printer, Quick Menu, “Reprint”*.

Replace Sheet Separators

Sheet Separators insure separation of pieces as they are being fed. They wear and must be replaced periodically. If you experience double sheet feeding and cannot adjust the Separators to prevent it, they should be replaced.

1. Turn OFF and unplug Printer.
2. Release Separator Locking Lever and move Media Side Guides to their maximum open position.
3. Lower Separators so they touch Feed Roller.
4. Remove screw [A] and Separator Support [B]. Then remove Separator [C] by prying it out of Holder.
5. Install a new Separator and reinstall Separator Support and screw.

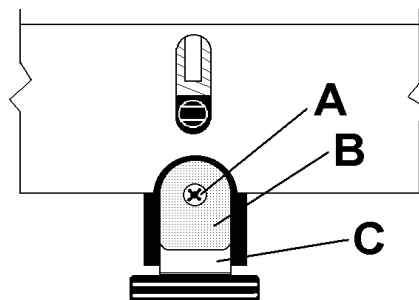

Cleaning

WARNING!

PRINTER IS A PRECISION MACHINE THAT SHOULD BE CLEANED REGULARLY TO INSURE MANY YEARS OF SERVICE. BEFORE PERFORMING ANY MAINTENANCE, DISCONNECT PRINTER FROM ITS POWER SOURCE!

Printer must be cleaned regularly of accumulated paper dust and ink. Depending on types of media that are run, paper dust may accumulate within Printer and on Transport. To properly clean Printer, unplug it from power receptacle and remove covers.

- **Internal Areas:** Best cleaned using a vacuum with a soft brush attachment to help loosen dust particles. Take care not to damage PC Boards or electrical wiring.
- **Exterior Areas:** May be cleaned with any standard non-abrasive household cleaner that does not contain plastic-harming solvents.

CAUTION

NEVER SPRAY OR POUR CLEANERS DIRECTLY ON OR INTO THE PRINTER. EXCESS LIQUID COULD HARM ELECTRONIC PARTS. ALWAYS DAMPEN A RAG WITH THE CLEANER AND APPLY IT TO THE PARTS TO BE CLEANED.

Feed Rollers and Forwarding Rollers

Feed and Forwarding Rollers can become glazed with paper lint and ink from media. They should be regularly cleaned with a mild abrasive household cleaner on a damp cloth. Avoid using solvents on Rubber Rollers.

Cleaning Media Sensor

Periodically check Media Sensor for dust and debris, (*located under Media Hold-down Wheel Assembly*).

1. Use the Media Thickness Knob to raise the Printhead Carriage Assembly to its highest setting.
2. Use canned or compressed air into the Media Sensor port [A] and under the Media Sensor Reflector [B] to remove dust and debris.

NOTE: If necessary, wipe the Reflector surface (*under the mounting plate*) with a clean, lint-free cloth.

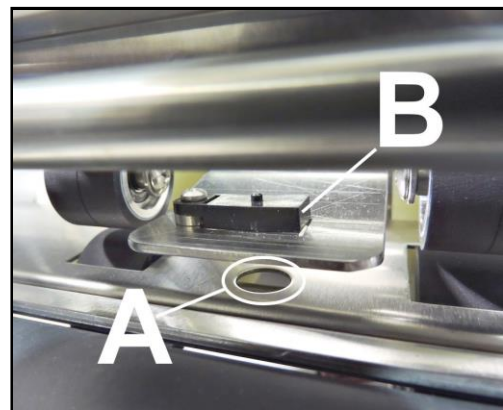

Cleaning Touchscreen

Carefully clean the Touchscreen by wiping with a lint-free cloth and a non-abrasive cleaner made for touchscreens on computers and cell phones. **DO NOT spray cleaner directly on screen, spray on cloth, then clean screen.**



SECTION 5 – *Troubleshooting Guide*

Troubleshooting Guides are provided to assist you in solving any problems that might occur with Printer or its software. We tried to make them as complete as possible. The best advice we can offer is to make sure that the system is setup properly, plugged in, has an adequate supply of ink before attempting to troubleshoot any problem.



WARNING!

**DO NOT REMOVE SIDE COVERS ON PRINTER!
HIGH VOLTAGES PRESENT BEHIND COVERS!**

Inkjet Print Cartridges

CONDITION	PROBLEM	SOLUTION
Black streaks in text This is a sample of text showing black streaks in the copy.	Lint or paper dust on Printhead.	Clean the Cartridge Nozzles with a clean lint-free cloth moistened with distilled water. Print a Purge Print . See “ Section 4 – Maintenance, ” Purging Nozzles.
Cartridge will not print	Sheet is blank even after it has gone underneath Cartridge(s).	Check to make sure protective tape is removed from Printhead. Remove and reinsert Ink Cartridge into Carriage Holder. Install new Print Cartridge.
White streaks in text or graphics Michael Jones Astro Machine Corp. 630 Lively Blvd. Elk Grove Village, IL 60007-1234	Lint or dust blocking Printhead holes. Poor contact between Printhead and Printhead Holder.	Clean the Cartridge Nozzles with a clean lint-free cloth moistened with distilled water. Print a Purge Print . See “ Section 4 – Maintenance, ” Purging Nozzles. Clean Interconnects. Remove and reinsert Ink Cartridge into Holder. Insert new Print Cartridge.

Printer

CONDITION	PROBLEM	SOLUTION
Extra lines; losing data	Database problem.	Check data in database program.
Improper output (address information out of order, misfeeding, etc.)	Wrong Interface settings. Static electricity. Dirty Media Sensor.	Check software or database on PC. Turn Printer OFF and ON. Clean Media Sensor.
	Paper jam. Media is curled or bent. Media is too thin. Sheet Separators need adjustment.	Clear media from feeder and/or print transport area. Uncurl media. Minimum media thickness: at least 0.008" (0.2 mm) thick. Adjust Sheet Separators on Feeder.
	No gap detected between pieces. Media size does not match the page size specified by the job.	Clear media from feeder and/or print transport area. Use Reprint (on <i>Quick Menu</i> screen) to retrieve/restore missing or misprinted pages in the print job.
No communication	Improper cabling / connector. Unit not receiving power.	Use proper cable (see <i>Operator Manual</i>). Check plug connections, ON/OFF Switch and Fuse on Back Panel (see <i>Operator Manual</i>).
Not printing on media	Media not positioned properly.	Adjust Printhead vertically. Adjust the margin setting in layout software.
Print too light or missing character dots	Clogged or dirty Printheads. Running out of ink.	Purge or clean Ink Cartridges. Replace Ink Cartridges.
Blurry address 	Image is not sharp.	Install new Ink Cartridge. Printhead gap too high. Adjust Printhead closer to the media.
Split line of type Astro Machine Corp. 630 Lively Blvd. Elk Grove Village, IL 60007	Line of type is placed across two Printheads.	Reposition text in layout so that it does not print across Printheads. Adjust positioning of Printheads in relation to each other using Head Alignment in Quick Menu on the Control Panel.
Uneven split line of type Astro Machine Corp. 630 Lively Blvd. Elk Grove Village, IL 60007	Some but not all of a line of type across two Printheads matches up.	Reposition text in layout so that it does not print across two Printheads. Check Sheet Separator adjustment. Separators should just touch media. Check Printhead height. If the Printhead is set too high it will cause media to slip as it passes under Heads.

**SECTION 5
TROUBLESHOOTING**

Touchscreen Messages

The Touchscreen will display messages to alert you to problems or to indicate a process is finished.

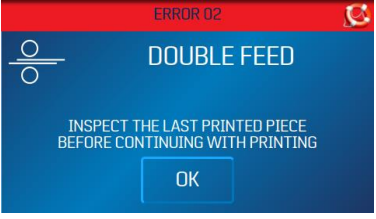
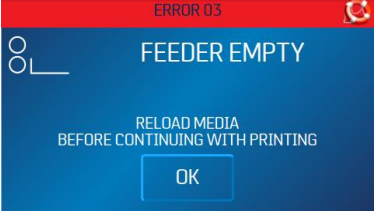
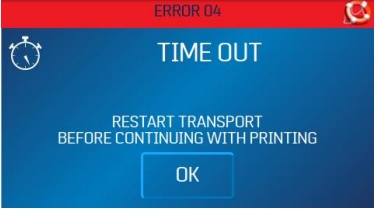
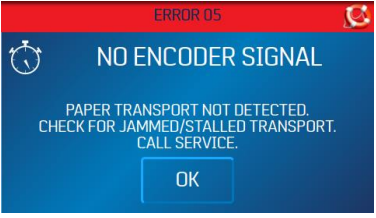
SCREEN MESSAGE	PROBLEM	SOLUTION
	<p>No gap detected between pieces. Media size does not match the page size specified by the job.</p>	<p>Clear media from feeder and/or print transport area. Use Reprint (on <i>Quick Menu screen</i>) to retrieve/restore any missing or misprinted pages in the print job. Press OK to continue.</p>
	<p>No media in Feeder/Hopper.</p>	<p>Reload media. Press OK to continue.</p>
	<p>Printer operation has timed out or Printer was paused too long.</p>	<p>Check Printer. Press OK to continue.</p>
	<p>Printer Motor has stopped. Wire Harness connection is loose or broken. Encoder Belt worn or broken. Encoder Sensor not working.</p>	<p>Check Printer Motor. Check J5 connector on I/O Board. Check Encoder Belt. Check Encoder Sensor.</p>

APPENDIX A – Specifications

PRINT TECHNOLOGY	6-Head Inkjet, proprietary High Capacity Inkjet Cartridges
ADDRESS SPEED	Up to 30,000/hour (#10 Envelopes)
PRINT QUALITY/SPEED (Dots Per Inch)	1-High Quality 600 x 600 DPI (25 in. /sec.; 125 ft. /min.; 38 m/min.) 2-Standard Quality 600 x 300 DPI (50 in. /sec.; 250 ft. /min.; 76 m/min.) 3-Letter Quality 600 x 200 DPI (75 in. /sec.; 375 ft. /min.; 114 m/min.) 4-Draft Quality 600 x 150 DPI (95 in. /sec.; 475 ft. /min.; 145 m/min.)
IMAGE AREA	3" x 15" (76.2 mm x 381 mm)
PRINT ORIENTATION	Right-to-Left
FONTS	All TrueType fonts available on PC
PRINTS	Prints graphics, logos, and barcodes
MEDIA SIZE (Minimum to Maximum)	Length: 5" to 15" (127 mm x 381 mm) Width: 2.75" to 14" (69.9 mm to 355.6 mm) (Printable: 10"/254 mm)
MEDIA THICKNESS	Minimum: 0.008" (0.2 mm) Maximum: 0.375" (9 mm)
FEEDER CAPACITY	Up to 750 #10 envelopes
PROCESSOR	600 Mhz Dual-core ARM Cortex-A9 MP Core
MEMORY	1 GB of DDR3-1600Mhz SDRAM 8 GB (<i>default</i>) microSD. Not externally accessible
PRINT COLORS	Proprietary water-based inks in Inkjet Cartridges
INK	Water-based, may require drying assistance for coated stock
INK MONITOR	Visible on Touchscreen Display
SOFTWARE	Windows™ compatible Printer Drivers for Windows™ operating systems
DIAGNOSTICS	Resident in firmware
FIRMWARE UPDATE	Flash PROM update
PC INTERFACE	Ethernet Port (10/100/1000Mhz) USB 3.1 Port (<i>also supports USB 2.0</i>) Wireless with external wireless to USB adapter
COUNTERS	Lifetime Piece Counter, Session Counter, Jobs Counter
DUTY CYCLE	60 million addresses total or 1,000,000 per month over a 5-year life cycle.
DIMENSIONS	21.25" H x 28.75" L x 23" W (54 cm H x 73 cm L x 58.4 cm W)
WEIGHT	80 lbs. (36.3 kg.)
ELECTRICAL	Switchable: 115VAC or 240VAC, 50/60 Hz
OPTIONS	Conveyor and Drop Tray

All Specifications Subject To Change Without Notice



Regulatory Compliance

FCC: "This device complies with Part 15 of the FCC Rules.

Operation is subject to the following conditions:

1. This device may not cause harmful interference.
2. This device must accept any interference received including interference that may cause undesired operation."

This Class A digital apparatus complies with Canadian ICES-003.

Cet appareil numérique de la classe A est conforme à la norme NMB-003 du Canada.

APPENDIX B – *Supplies and Optional Hardware*

The following supply items and optional hardware are available from your Astro Machine Dealer:

Supplies

IMPORTANT! AJ-140/AJ-160/AJ-180 Printers only work with the ink cartridges listed below. Other inks may become available; check with your local Astro dealer.

NOTE: Not compatible with refills or other brands.

INK TYPE	DESCRIPTION	PART NO.
AMC-MAX3	High performance, quick-drying, water/solvent-based black ink for aqueous varnished media, Tyvek, PVC and more.	123-3087
AMC-Superfast	General purpose, quick-drying, dye-based black ink for uncoated and some coated media.	123-3088
AMC-Complete	All-purpose black dye/pigmented hybrid-based ink for a wide range of coated and uncoated media with dark black print.	123-3188
AMC-Blue	Spot color blue pigmented hybrid-based ink for a variety of coated and uncoated media.	123-3089
AMC-Red	Spot color red pigmented hybrid-based ink for a variety of coated and uncoated media.	123-3090
AMC-Green	Spot color green pigmented hybrid-based ink for a variety of coated and uncoated media.	123-3179
AMC-Security	"Invisible" ink is visible under UV light. Works with aqueous varnished media, Tyvek, PVC and more.	123-3203
AMC-Solvent	High performance black solvent-based ink for UV-coated and nonporous media including plastics, PVC, aluminum and more.	123-3085
AMC-Bear	Economical dark gray solvent-based ink for nonporous media and coated or varnished stock.	123-3086

Optional Hardware

DESCRIPTION	PART NO.
Conveyor	CDM-700
Drop Tray	DTM-250

INDEX

A

Alphanumeric Keyboard.....18
 Antenna, Wi-Fi7
 Assemble Printer.....5

C

Calibration, Touchscreen29
 Cartridge Initialize Button29

Cartridges

Inkjet.....10, 35
 Printhead.....37
 Choose Location5

Cleaning

Feed Rollers39
 Forwarding Rollers39
 Media Sensor39
 Printhead.....37
 Touchscreen.....39
 Compliance, Regulatory44

Connect

Computer7
 Network7
 Printer7
 Wi-Fi Antenna7
 Contents of Packaging5

Control Panel

Feeder ON/OFF Key3
 Keys1, 2
 Power Off/Restart Key3
 Printer1
 Quick Menu Key3, 30
 Shutdown Printer Button29
 Touchscreen.....1, 2, 3
 Transport ON/OFF Key3

D

Date and Time28
 Diagnostics27

Display

Cleaning.....39
 Printer1, 2, 3
 Using.....17
 Disposal, Inkjet Cartridges37

E

Ethernet Port2, 7

Exit Guides

Adjust11
 Location.....1

F

Factory Default24
 FCC Compliance44
 Feed Rollers, Cleaning39
 Feed, Set-Up11

Feeder ON/OFF Key3
 Firmware Updates.....29
 Forwarding Rollers, Cleaning.....39
 Fuse2

G

Guides

Exit1, 11
 Rear Media1, 2, 11
 Side Media.....1, 2, 11
 Side, Install6

H

Hardware, Optional45
 Horizontal Alignment, Printhead25

I

Indicator Light, Power1, 2
 Ink Estimator26
 Ink Nozzles, Purge.....38
 Ink Status26
 Ink Type Screen.....22

Inkjet Cartridges

Disposal37
 Install10
 Maintenance.....35
 Replace36
 Storage.....37
 Troubleshooting40

Install

Inkjet Cartridges10
 Printer5
 Printer Driver.....13
 Printer Update Utility Software15
 Rear Media Guide.....6
 Rear Media Support.....6
 Side Guides.....6

J

Jams, Printer38

K

Keys, Control Panel1, 2

L

Language, Select.....24
 Location, Choose5
 Locking Lever, Separator2

M

Main Menu19
 Main Power Switch2

Maintenance

Cleaning39
 Inkjet Cartridges35
 Sheet Separators38

Media Sensor	
Cleaning	39
Location	1
Media Thickness Adjustment	1, 2
Messages, Touchscreen	42
N	
Network Port	7
Network Settings	27
Nozzles, Printhead	38
P	
Port Reset Button	29
Power Button	29
Power Indicator Light	1, 2
Power Off/Restart Key	3
Power Receptacle	2
Print Image Screen	20
Printer	
Assemble	5
Cleaning	39
Connect	7
Control Panel	1, 2
Ethernet Port	2
Exit Guides	11
Firmware Updates	29
Fuse	2
Install	5
Jams	38
Main Power Switch	2
Maintenance	35
Media Sensor	1
Media Side Guides	1, 2
Media Thickness Adjustment	1, 2
Network Settings	27
Operating	17
Package Contents	5
Power Indicator	1, 2
Power Receptacle	2
Preferences	23
Printhead Assembly	1
Rear Media Guide	1, 2, 6
Rear Media Support	1, 2, 6
Set-up Screen	22
Sheet Separators	2, 38
Specifications	43
Supplies & Hardware	45
Time Server	28
Tools	25
Troubleshooting	40, 41
Update Utility, Install	15
USB Port	2
Wi-Fi Port	2
Wi-Fi Set-up	28
Wireless Status	27
Printer Driver	
Install	13
Properties	31
Printhead	
Assembly	1
Cleaning	37
Safety Cover	1
Purge Ink Nozzles	38
Q	
Quick Menu Key	3, 30
R	
Rear Media Guide	
Adjust	11
Location	1, 2
Rear Media Support	1, 2
Rear Media Support and Guide	6
Regulatory Compliance	44
Remove/Replace	
Inkjet Cartridge	36
Inkjet Cartridges	35
Jams, Media	38
Sheet Separators	38
Restart Button	9, 29
Rollers, Cleaning	39
S	
Safety Cover, Printhead	1
Sensor, Cleaning Media	39
Separator Locking Lever	2
Set-Up	
Feed	11
Network	27
Printer	22
Wi-Fi	28
Sheet Separators	2
Adjust	11
Maintenance	38
Shutdown Button	8, 29
Side Guides	
Adjust	11
Install	6
Media	1, 2
Sleep Now Button	29
Software, Printer Update Utility	15
Specifications	43
Storage, Inkjet Cartridges	37
Supplies, Printer	45
Support, Rear Media	2
Switch	
Main Power	8
On/Off	8
Switch, Power	2
T	
Thickness Adjustment, Media	1, 2
Tools, Printer	25

INDEX

Touchscreen

Alphanumeric Keyboard	18
Calibration	29
Cleaning	39
Control Panel	1, 2, 3
Diagnostics	27
Horizontal Alignment, Printhead	25
Ink Estimator	26
Ink Status	26
Ink Type.....	22
Main Menu	19
Messages.....	42
Print Image Screen.....	20
Printer Preferences.....	23
Printer Set-up Screen	22
Printer Tools	25
Select Language.....	24
Using.....	17
Vertical Alignment, Printhead	25
Transport ON/OFF Key.....	3
Troubleshooting	40
Inkjet Cartridges	40
Printer	41
Touchscreen Messages	42
U	
Update Utility, Install Printer	15
Update, Firmware	29
USB Disconnect Button.....	29
USB Port.....	2, 7
Using Touchscreens.....	17
V	
Vertical Alignment, Printhead	25
W	
Wi-Fi	
Antenna.....	7
Port	2, 7
Set-Up.....	28
Wireless Status	27

Copyright © 2020 **ASTRO MACHINE CORP.**

Elk Grove Village, IL 60007

11/23/2020

Part Number: 200-AJ160
